

2022-2023 PORTFOLIO



arc
cardinal

CARDINAL EVERYWHERE

Our cover was inspired by our Arc Cardinal products at the finest restaurants, trendiest hotels, and Instagram-worthy cocktail bars!

Each of our collections has been expertly crafted and designed to support the needs of today's chefs, mixologists and sommeliers. This visionary approach to tableware is the founding principle of our culture and brands - Chef & Sommelier®, Arcoroc®, Dudson, Sola, Richardson Sheffield, Chasseur, Thermos®, Alfi® and Abert Buffetware.

We are continuously being inspired by our partners and customers as they transform their tabletops. We know not every establishment has the same budget, customers and operational demands. We set out to serve our customers' needs with solutions. From hotels to healthcare and casual dining to university and colleges, we have you covered.

Our mission is to set new standards of excellence through innovative product design, technological advancement, & extraordinary customer service.

TRUSTED AND TRUE

As part of Arc International, founded in 1825, we will always stay true to our roots of quality, durability, and value. And will always be your first -and most trusted - source for tableware.



Power of Pride

You can trust the pride we take in our product development. Our brands offer timeless, European design principles translated for today's global tables and trends, showing our passion and understanding for the food and beverage service.

Arc Cardinal Brands

Tableware that stands up to the demands of your busy operation.

Corporate Brands



ARCOROC

Partner Brands



Showrooms

Totowa, NJ

New York, NY

Miami, FL

Los Angeles, CA

New Website!

www.ArcCardinal.com

Arc Cardinal Valued Partners



We are proud to support and partner with The USA & Canada delegation of the Association of Maîtres Cuisiniers de France (MCF). MCF accepts only the best French Chefs in the world. Being a Maître Cuisinier (or Master Chef of France) is a prestigious honor that is held in high regard. These chefs are given the highest classification in restaurant guides and are regularly mentioned in top food and travel publications. MCF's motto is, "To preserve and spread the French culinary arts, encourage training in cuisine, and assist in professional development."

We are very pleased to be partnering with such a illustrious organization!



We are so proud to be partners with the United States Bartenders' Guild (USBG). Their mission is to unite the hospitality community to advance professional bartending. The USBG empowers bartenders to take charge of their careers and works to enrich the career advancement of its members through peer-to-peer learning, expert instruction, service projects and competition. We are grateful to be partners with the USBG!

For more information go to www.usbg.org



Slow Food USA[®]

Arc Cardinal is proud to continue our journey of sustainability by partnering with Slow Food USA to support the Chef's Alliance in the commitment to good, clean, and fair food for all.



arc
cardinal

preview of new PRODUCTS

MORE INSIDE...



Sequence Nick and Nora (Page 15 and 90)



Dudson Organic White (Page 140)



Mix & Play Set A, B and C (Page 266)



Dudson Harvest Turquoise (Page 142)



Broadway Vintage (Page 75 & 92)



Dudson Harvest Plum (Page 142)



Domino and On Stage Collections (Page 246 & 255)



Chef & Sommelier Black Oak Satin (Page 217)

DRINKWARE 10

Stemware

Amelia	42
Artic	43
Cabernet	16
Elegance	44
Exalt	30
Excalibur	38
Macaron	24
Malea Brio	37
Mineral	36
Open Up	28
Reveal' Up	26
Romeo	34
Rutherford	45
Sequence	12
Sublym	22
Villeneuve by Chef Daniel Boulud	10
V.Juliette	32

Tumblers & Barware

Arcadie	56
Architecte	51
Aristocrat	77
Aska	48
Artic	62
Be Bop	68
Brixton	72
Broadway	74
Cabernet	78
Cabernet Sheer	47
Cooler	88
Essentials	66
Excalibur	63
Gotham	58
Granite	64
Islande	72
Lima	49
Macaron	46
Macassar	51
Malea	53
Mason Jars	86
Milk Jars	87
Monroe	89
Moscow Mules	84
New York	65
Norvege	62
Open Up	46
Perfection	77
Precision	54
Primary	50
Primary Arpege	50
Princesa	64
Prysm	55
Room Tumblers	89
RendezVous	52
Salto	79
Sequence	56
Shetland	76
Stack Up	60
Urbane	70
V.Juliette	53

Wine Bottom Tumblers	80
Working Glass	85

Cocktails

After Dinner	104
Martinis · Coupes	90
Shots	102
Sparkling Wine	94
Whiskey	98

Beer

Footed Beer	107
Mixing/Pub	110
Pilsners	112
Premium Beer	106
Mugs	125
Samplers	114

Decanters & Carafes

Decanters and Carafes.....	116
Fluid Carafes.....	120
Pitchers.....	122
Swing Top Bottles.....	118

Accessories

Accessories	123
Ashtrays	123
Mix Collection	124

S. A. N. Plastic

Outdoor Perfect	128
Outdoor Perfect Stackable	131

DINNERWARE 132

Dudson Dinnerware

Acacia Wood	151
EVO Origins	146
EVO	148
Harvest	142
Harvest Norse	138
Organic White	140
The Maker's Collection: FINCA	136
The Maker's Collection: URBAN	134

Chef & Sommelier® Dinnerware

Eternity Plus	154
Geode	152
Infinity	158
Infinity Coupes	160
Nectar	162

Arcoroc® Dinnerware

Appetizer	172
Brush	198
Candour	182
Candour Azure	186
Candour Cirrus	184
Candour Coupes	180
Canyon Ridge	164
Capitale	190
Daring	170
Evolutions- Granite.....	196
Evolutions- Black	197
Horizon	178
Intensity	206
Mekkano	166

Opal Dinnerware	192
Restaurant White	219
Rondo	176
Smart Cuisine	200
Square Up	168
Upcycle	174
Variations	175
Versatile	175
Vintage	188

Arcoroc® Glass Dinnerware

Arcade Bowls	206
Fleur	210
Dessert	212
Glass Coffee Mugs	211
Keep N Box	202
Louison	208
Roc	211
Stack Bowls	206
Stack Bowl w/ Lid	207
So Urban	204

FLATWARE 214

Chef & Sommelier® Flatware

Black Oak 18/10	216
Black Oak Satin 18/10	217
Diaz 18/10	217
Ezzo 18/10	218
Finn 18/10	218
Fluted 18/10	219
Harper 18/10	219
Knox 18/10	220
Kya 18/10	220
Kya Sand 18/10	221
Kya Black 18/10	221
Lazzo 18/10	222
Lure 18/10	222
Nectar 18/10	223
Orzon 18/10	223
Orzon Patina 18/10	224
Renzo 18/10	224
Renzo Patina 18/10	225
Steak Knives	242
Universal Serving Accessories 18/10	216

Sola Flatware

3 Piece To Go Flatware	233
Atlantic 2000 18/10	226
Atlantic 2000 Specialty Items 18/10	226
Alessandria 18/10	227
Baguette Black 18/10	227
Baguette Copper 18/10	228
Baguette Gold 18/10	228
Baguette Vintage Stone Wash 18/10	229
Cloud 18/10	229
Eve 18/10	230
Imperial Chopsticks	230
Living Mirror 18/10	231
Living Mirror Specialty Items	231
Living Satin 18/10	232
Luxus Sand 18/10	232
Miracle 18/10	233

Arcoroc® Flatware

Amber 18/0	238
Burlington 18/10	234
Capitale 18/0	239
Empire 18/10	235
Greenwich 18/0	239
Harrison 18/0	240
Latham 18/10	235
Latham Sand 18/10	236
Liv 18/0	240
Matiz 18/10	236
Mikayla 18/0	241
Satineo 18/0	241
Steak Knives	243
Stone 18/10	237
Stone Satin 18/10	237
Universal Serving Accessories 18/10	234
Vesca 18/10	238

SMALLWARES/BUFFETWARE 244

Display/Risers

Abert

Domino	246
Cosmo	242
On Stage	255
Mix & Play	254

Beverage Service

Alfi

Albergo	256
Gusto Top Therm	258
Hotello	260
Lightweight Carafe	262

Thermos

Accessories	272
Brew In Carafe	264
Carafe w/ Gauge	266
Carafe w/ Lever	268
Twist and Pour	270

Cookware/Serveware

Chasseur

Round & Oval Casserole	274
Round & Oval Low Casserole	276
Round & Oval Dish	280
Terrine Rectangle Gratin	278
Trivets	280

Cutlery

Richardson Sheffield Professional Cutlery

Asean	284
Origin	288
Pro Flex	290
R Cut	291
Universal	286
Vulcano	282

CUSTOM DECORATION 292

Care & Handling	297
Index	305



GLASSWARE

Equal Parts Strength And Style

Smart buyers turn to Arc Cardinal time and time again for our unmatched strength and technological innovation. We feature palate-pleasing designs, the perfect shapes and sizes, natural pour lines and stackability—along with the unmatched strength and technological innovation that has long made our glassware the industry standard.

A true heritage of French gastronomy, the Chef & Sommelier brand offers high-end collections for tasting. Sleek stems, audacious bowls and sheer rims allow for one to experience the subtle notes in every sip.



The Chef & Sommelier collections allow to sublimate the creativity and talent of professionals thanks to an innovative material: Krysta.

Superior resistance, total transparency, long-lasting brilliance and perfect acoustics: everything is combined to meet the most demanding specifications.

Arcoroc's glassware collections support the creativity and desires of customers with innovative designs and durable materials.



Each product is designed for intensive use, and can stand up to the daily rigors across bars and restaurants.

In addition to the technical qualities that are essential for professionals, Arcoroc glassware is trendy, functional and offers the wow factor bartenders look for when presenting their beverages.



Crafted Excellence

Krysta® – High-performance crystal glass. A new generation of lead-free crystal exceeding 2,000 industrial dishwashing cycles. Superior strength, complete transparency, long-lasting brilliance and perfect acoustics.



ArmoRIM® – A thermal strengthening after-process for rim reinforcement and chip resistance.



Sheer Rim – Fine rims add for a refined customer experience while providing extra durability to the rim.



Performance Enhancing

Effervescence Plus – A technology that develops even, delicate bubbleness, delighting the eyes and taste buds alike. This feature is indicated by an asterisk (*) next to the glass within each collection.



Performance Nucleation – Promotes constant flow of carbon dioxide bubbles to steadily release aromas critical for enjoying beer.



Stackability – Product design specifically made for safe stacking.



Safeguard the Arc Way

Developed by Arc

Fully Tempered – More resistant to mechanical and thermal shock than regular annealed glass; up to 5X more resistant to breakage.



S.A.N. Plastic – Fully recyclable, BPA-free, and dishwasher safe- up to 2,000 industrial dishwashing cycles.



VILLENEUVE BY DANIEL BOULUD



Meticulously crafted by Daniel Boulud, each glass allows for the true appreciation of the wine, capturing the story of each varietal that is being tasted. This collection seamlessly transitions from fine dining to bistro.

NEW

VILLENEUVE BY DANIEL BOULUD

* EFFERVESCENCE PLUS

C&S
Chef & Sommelier
- FRANCE -

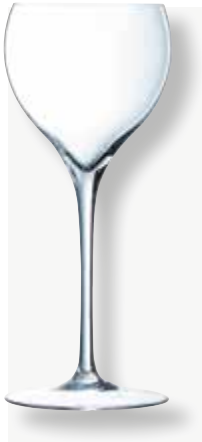

FN159
Sweet Wine (9 Oz.)
H: 7 15/16" T: 3"
B: 3 3/8" M: 3 5/16"
1 Dz.



FN166
Universal Wine (16 Oz.)
H: 8 15/16" T: 2 7/16"
B: 3 1/4" M: 3 1/2"
1 Dz.



FN161
Universal Wine (18 Oz.)
H: 9 3/4" T: 2 1/2"
B: 3 1/2" M: 3 1/2"
1 Dz.



FN160
Burgundy (21 1/2 Oz.)
H: 8 15/16" T: 2 13/16"
B: 3 1/2" M: 4 1/8"
1 Dz.



FN162
Bordeaux (24 1/2 Oz.)
H: 10 1/8" T: 2 7/8"
B: 3 1/2" M: 4"
1 Dz.



Q1151
Exaltation Specialty Flute (10 1/4 Oz.)
H: 8 5/16" T: 2 5/16"
B: 2 7/8" M: 3 1/16"
2 Dz.

*

TECHNOLOGY & MATERIAL



★
★
★
★
★
★
STEMWARE



The Glassware Sequence Of The Future. The perfect design progression, bringing a modern update to a classical shape with the essence of crafted crystal. Made with our high-performance lead-free crystal material, Krysta®.



N9696
 Port (7 Oz.)
 H: 7 1/2" T: 1 3/4"
 B: 2 5/8" M: 2 1/2"
 2 Dz.



L5635
 Universal (13 Oz.)
 H: 8 1/4" T: 2 1/4"
 B: 3" M: 3 1/8"
 1 Dz.



L5633
 Universal (16 Oz.)
 H: 9" T: 2 7/16"
 B: 3 1/4" M: 3 7/16"
 1 Dz.

NEW



9 oz.
 6 oz.

Q1069
 Corkscrew Universal
 (16 Oz.)
 H: 9" T: 2 3/8"
 B: 3 1/4" M: 3 5/16"
 1 Dz.
 6 OZ. Bottom of Corkscrew
 9 OZ. Top of Corkscrew
 Approximate Pour Lines



L5638
 Universal (19 1/2 Oz.)
 H: 9 1/4" T: 2 5/8"
 B: 3 1/2" M: 3 3/8"
 1 Dz.



L5636
 Burgundy (20 1/2 Oz.)
 H: 8" T: 2 5/8"
 B: 3 3/8" M: 3 7/8"
 1 Dz.



N9710
 Bordeaux (21 Oz.)
 H: 9 1/4" T: 2 3/4"
 B: 3 1/2" M: 3 3/4"
 2 Dz.



L5637
 Bordeaux (26 Oz.)
 H: 9 3/8" T: 2 5/8"
 B: 3 3/8" M: 3 1/2"
 1 Dz.

For Tumblers See Page 46

TECHNOLOGY & MATERIAL



★ ★ ★ ★ ★
 S T E M W A R E



Brilliant and resilient, Sequence delivers an authentic yet elevated craft cocktail experience.



*

L5640
 Flute (6 Oz.)
 H: 8 ¼" T: 1 7/8"
 B: 2 ¾" M: 2 ¼"
 1 Dz.

NEW



Q3702
 Nick and Nora Cocktail (5 ¼ Oz.)
 H: 5 5/8" T: 2 ¾"
 B: 2 3/8" M: 2 ¾"
 2 Dz.



L5641
 Coupe Cocktail (7 ¾ Oz.)
 H: 5 7/8" T: 4 3/8"
 B: 3" M: 4 3/8"
 1 Dz.



L5642
 All Purpose (14 Oz.)
 H: 6 9/16" T: 2 ½"
 B: 3" M: 3 1/8"
 1 Dz.



N9711
 Iced Tea (16 Oz.)
 H: 7 ¼" T: 2 ¾"
 B: 3" M: 3 3/8"
 2 Dz.



P0089
 Belgian Beer (12 ½ Oz.)
 H: 5 7/8" T: 2 ½"
 B: 2 7/8" M: 3 ¼"
 2 Dz.

For Tumblers See Page 46

TECHNOLOGY & MATERIAL



★
 ★
 ★
 ★
 ★
 ★
 S T E M W A R E

C&S
Chef & Sommelier CABERNET
- FRANCE -



A wide range of sizes with superior strength; it's a perfect blend of elegance and endurance.



FJ036
Bordeaux (16 Oz.)
H: 8 ½" T: 2 ¾"
B: 3 ½" M: 3 ¾"
1 Dz.



FJ035
Bordeaux (21 ¼ Oz.)
H: 9 ½" T: 2 ¾"
B: 3 ½" M: 3 ¾"
1 Dz.



FJ037
Burgundy (24 Oz.)
H: 8 ⅝" T: 2 ⅞"
B: 3 ½" M: 4 ⅜"
1 Dz.



46978
Tall Wine (8 ½ Oz.)
H: 7 ⅞" T: 2 ¼"
B: 2 ¾" M: 2 ⅞"
2 Dz.



50816
Tall Wine (10 ½ Oz.)
H: 7 ¾" T: 2 ¾"
B: 3" M: 3 ¼"
2 Dz.



46973
Tall Wine (12 Oz.)
H: 8" T: 2 ½"
B: 3" M: 3 ⅜"
2 Dz.



46961
Tall Wine (16 Oz.)
H: 8 ⅝" T: 2 ¾"
B: 3" M: 3 ½"
2 Dz.

For Tumblers See Page 47

TECHNOLOGY & MATERIAL



★
★
★
★
★
STEMWARE



9 oz.
 6 oz.



L0571
 Tall Wine with pour line (16 Oz.)
 H: 8 5/8" T: 2 3/4" B: 3" M: 3 1/2"
 2 Dz.
 6 OZ. Bottom of Grapes
 9 OZ. Top of Grapes
 Approximate Pour Lines



46888
 Tall Wine (19 3/4 Oz.)
 H: 9 1/16" T: 2 13/16"
 B: 3 1/4" M: 3 1/16"
 2 Dz.



D0795
 Tall Wine (25 1/4 Oz.)
 H: 10" T: 3"
 B: 3 1/8" M: 3 15/16"
 1 Dz.

For Tumblers See Page 47

TECHNOLOGY & MATERIAL





47019
 Ballon Wine (12 Oz.)
 H: 7 3/16" T: 2 7/8"
 B: 3" M: 3 5/8"
 2 Dz.



47017
 Ballon Wine (16 Oz.)
 H: 7 3/4" T: 3"
 B: 3" M: 3 15/16"
 2 Dz.



47026
 Ballon Wine (20 Oz.)
 H: 8 1/4" T: 3 3/16"
 B: 3 1/4" M: 4 3/16"
 2 Dz.



46981
 Ballon Wine (24 Oz.)
 H: 8 1/16" T: 3 3/8"
 B: 3 1/4" M: 4 1/2"
 2 Dz.



E2788
 Young Wine (12 Oz.)
 H: 7 7/8" T: 2 1/4"
 B: 3 3/16" M: 3 1/2"
 2 Dz.
 3 1/2 Oz. pour line



E2790
 Young Wine (16 Oz.)
 H: 8 1/2" T: 2 5/8"
 B: 3 1/4" M: 3 13/16"
 2 Dz.
 4 Oz. pour line



E2789
 Young Wine (19 1/2 Oz.)
 H: 8 7/8" T: 2 3/4"
 B: 3 3/16" M: 4 1/8"
 2 Dz.
 5 1/2 Oz. pour line



P0112
 Millesime Wine (15 3/4 Oz.)
 H: 8 3/8" T: 2 3/4"
 B: 3 1/4" M: 3 3/8"
 2 Dz.

For Tumblers See Page 47

TECHNOLOGY & MATERIAL





E5358
Cordial (2 ¼ Oz.)
H: 5 ¼" T: 1 ⅝"
B: 2" M: 1 ⅞"
2 Dz.



14798
Port (4 Oz.)
H: 5 ⅞" T: 1 ⅝"
B: 2" M: 2 ⅛"
2 Dz.



48024
Flute (6 Oz.)
H: 8 ⅞" T: 2"
B: 2 ¾" M: 2 ¼"
2 Dz.



E6250
Flute (8 Oz.)
H: 9 ¼" T: 1 ⅞"
B: 2 ½" M: 2 ½"
2 Dz.

For Tumblers See Page 47

CABERNET

* EFFERVESCENCE PLUS

KRYSTA®

C&S
Chef & Sommelier
- FRANCE -



D0796
Flute (8 Oz.)
H: 9 1/4" T: 2"
B: 2 3/4" M: 2 7/16"
2 Dz.



G3573
All Purpose (13 1/2 Oz.)
H: 6 5/16" T: 2 7/8"
B: 3 1/16" M: 3 3/16"
2 Dz.



G3570
Iced Tea (16 Oz.)
H: 7 7/16" T: 2 5/8"
B: 3 1/16" M: 3 3/16"
2 Dz.



N6887
Cocktail (7 1/2 Oz.)
H: 6 3/4" T: 4 1/2"
B: 3" M: 4 1/2"
1 Dz.



N6831
Cocktail (10 Oz.)
H: 7 1/2" T: 4 3/4"
B: 3" M: 4 3/4"
1 Dz.



N6815
Champagne Coupe (10 Oz.)
H: 6 3/4" T: 4 3/8"
B: 2 7/8" M: 4 5/8"
1 Dz.

For Tumblers See Page 47

TECHNOLOGY & MATERIAL



★
★
★
★
★
★
STEMWARE



Elegant & Timeless Design. The Sublym collection brings classic sophistication with a high and narrow bowl design. Designed with no seam, an extra flat foot and an elegant stem. Beautifully complementing Chef & Sommelier® Lima collection tumblers.



L2609
Wine (8 ¾ Oz.)
H: 8 ½" T: 2"
B: 2 ¾" M: 2 ¾"
2 Dz.



L2761
Wine (13 Oz.)
H: 9 ¼" T: 2 ¼"
B: 3" M: 3 ½"
2 Dz.



N1739
Wine (16 ½ Oz.)
H: 9 7/8" T: 2 3/8"
B: 3" M: 3 3/8"
1 Dz.



N1744
Wine (20 ¼ Oz.)
H: 10 ¼" T: 2 ½"
B: 3 ¼" M: 3 5/8"
1 Dz.

*



L2762
Flute (7 ½ Oz.)
H: 9 ½" T: 1 ¾"
B: 2 ¾" M: 2 ¼"
2 Dz.



L3678
Coupe Cocktail (8 Oz.)
H: 7 ½" T: 4 ½"
B: 3" M: 4 ½"
2 Dz.



N4742
Ballon (21 ¼ Oz.)
H: 9 ½" T: 2 ¾"
B: 3 ¼" M: 4 ½"
1 Dz.



N5368
All Purpose (13 Oz.)
H: 7 ¼" T: 2 ¼"
B: 3" M: 3 ½"
2 Dz.

TECHNOLOGY & MATERIAL



★
★
★
★
★
★
STEMWARE



Audacious round silhouette with dual bowl indentations designed to open the aromas of wine for a pleasurable tasting experience. Natural gauges facilitate portion control for wine by the glass service.

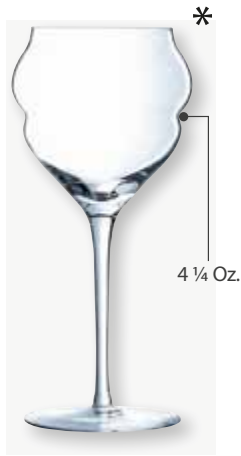

L9348
 Flute (10 Oz.)
 H: 7 5/8" T: 2 1/2"
 B: 3" M: 3 1/8"
 2 Dz.



L9267
 Wine (13 1/2 Oz.)
 H: 8" T: 2 5/8"
 B: 3" M: 3 5/8"
 2 Dz.



L9412
 Wine (16 1/2 Oz.)
 H: 8 1/2" T: 2 7/8"
 B: 3" M: 4"
 2 Dz.



L9414
 Wine (20 1/4 Oz.)
 H: 9 1/4" T: 3"
 B: 3 1/8" M: 4 1/8"
 1 Dz.

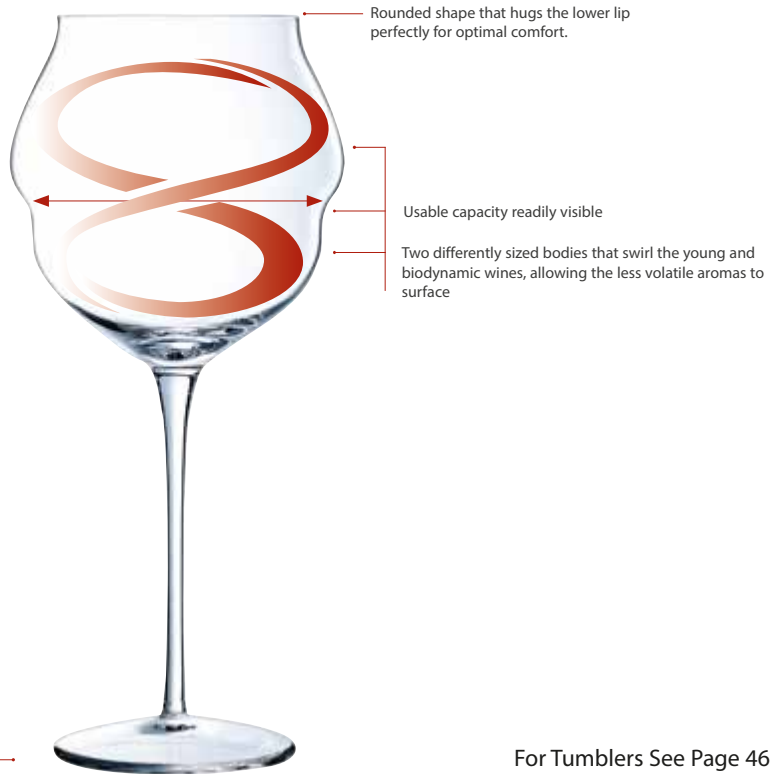

A non linear design to give your table a distinctive look

For Tumblers See Page 46

TECHNOLOGY & MATERIAL





- 5 CHIMNEY
> Lower alcohol perception
 - 4 SHEER RIM (0.9mm)
> Pleasant touch on lips
 - 3 RIM CLOSING OF THE BOWL
> Aromas concentration
 - 2 AROMATIC CHAMBER
> Aromas development
 - 1 OXYGENATION SURFACE
> Aromas source
- TASTE
- SMELL
- LOOK

1 Natural Gauge 2-4 Oz.

1 Collection, 2 Modern Shapes to enhance your wine service: Intense and Soft

- Intense: Extra-large oxygenation surface for perfect tasting of red, young or mature, strong and tannic wines.

- Soft: Large oxygenation surface and smaller opening of the bowl for perfect tasting of young and mature, red and white soft wines.



Contemporary and revolutionary design suitable for tasting all types of young wines with its large oxygenation area and closed rim to facilitate the concentration of flavors.



U1008
Pro Tasting (10 3/4 Oz.)
H: 7" T: 2 1/8"
B: 2 3/4" M: 3 1/4"
2 Dz.
1 1/4 Oz. pour line



U1010
Round (12 1/2 Oz.)
H: 8 1/4" T: 2 11/16"
B: 3" M: 3 3/4"
2 Dz.
3 1/4 Oz. pour line



U1011
Universal Tasting (13 1/2 Oz.)
H: 9" T: 2 3/8"
B: 3" M: 3 1/2"
2 Dz.
2 Oz. pour line



U1012
Soft (15 3/4 Oz.)
H: 8 7/8" T: 2 7/16"
B: 3 1/4" M: 4"
2 Dz.
3 Oz. pour line



U1013
Tannic (18 1/2 Oz.)
H: 9 1/8" T: 2 3/4"
B: 3 1/4" M: 4 1/8"
2 Dz.
3 1/2 Oz. pour line



U1051
Flute (6 3/4 Oz.)
H: 9" T: 2 3/8"
B: 2 13/16" M: 2 3/4"
2 Dz.
4 Oz. pour line

*

For Tumblers See Page 46

TECHNOLOGY & MATERIAL



★ ★ ★ ★ ★
STEMWARE

C&S

Chef & Sommelier

- FRANCE -

EXALT



SHEER RIM
1.2 mm



The alliance between perfect curves and incredible resistance coupled with the harmony of continuous and elegant lines.



E7698
Wine (6 ¾ Oz.)
H: 7 ¼" T: 2 ¼"
B: 2 ¾" M: 2 ¾"
2 Dz.



E7697
Wine (8 ¼ Oz.)
H: 7 ½" T: 2 ¾"
B: 2 ¾" M: 3"
2 Dz.



E7696
Wine (10 ½ Oz.)
H: 7 7/8" T: 2 ½"
B: 3" M: 3 ¼"
2 Dz.



E7695
Wine (13 ¾ Oz.)
H: 8 ½" T: 2 ¾"
B: 3 ½" M: 3 ½"
2 Dz.



E7700
Flute (6 ¼ Oz.)
H: 8 ¼" T: 2"
B: 2 ¾" M: 2 ¾"
2 Dz.

TECHNOLOGY & MATERIAL



★
★
★
★
★
★
STEMWARE

ARCOROC V. JULIETTE



The angular design of the V. Juliette collection offers a distinctive shape that fits very well with all table styles.

NEW

V. JULIETTE ARCOROC

* EFFERVESCENCE PLUS



N5163
Wine (10 Oz.)
H: 7 3/8" T: 2 1/8"
B: 2 5/8" M: 3 1/8"
2 Dz.



N4907
Wine (13 1/2 Oz.)
H: 8 1/8" T: 2 1/4"
B: 3" M: 3 3/8"
2 Dz.



N5993
Wine (16 3/4 Oz.)
H: 8 1/2" T: 2 1/2"
B: 3 1/8" M: 3 5/8"
2 Dz.



N5082
Flute (7 3/4 Oz.)
H: 8 5/8" T: 1 7/8"
B: 2 7/8" M: 2 5/8"
2 Dz.

For Tumblers See Page 53

TECHNOLOGY & MATERIAL

ARMORIM
HIGH RIM RESISTANCE



★ ★ ★ ★
STEMWARE

ARCOROC ROMEO



Tulip shape(s) and sheer rim makes the Romeo Collection the go-to choice for universal wine service.

NEW

ROMEO ARCOROC



P8794
Wine (12 Oz.)
H: 7 7/8" T: 2 1/2"
B: 3" M: 3 1/8"
1 Dz.



P8792
Wine (16 Oz.)
H: 8 3/8" T: 2 7/8"
B: 3" M: 3 3/8"
1 Dz.

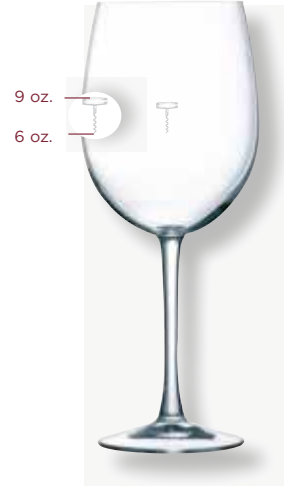

Q1095
Corkscrew Wine (16 Oz.)
H: 8 3/8" T: 2 7/8"
B: 3" M: 3 3/8"
1 Dz.
6 OZ. Bottom of Corkscrew
9 OZ. Top of Corkscrew
Approximate Pour Lines



P8790
Wine (19 Oz.)
H: 8 7/8" T: 2 7/8"
B: 3" M: 3 5/8"
1 Dz.



P8793
Flute (5 3/4 Oz.)
H: 7 7/8" T: 2"
B: 2 3/8" M: 2 1/8"
1 Dz.



P8782
All Purpose/ Beer (16 Oz.)
H: 7" T: 2 7/8"
B: 3" M: 3 1/4"
1 Dz.

TECHNOLOGY & MATERIAL

ARMORIM
HIGH RIM RESISTANCE



★
★
★
★
STEMWARE



*



H2090
Flute (5 ¼ Oz.)
H: 8 ¾" T: 1 ¾"
B: 2 ½" M: 2 ⅛"
2 Dz.



H2316
Wine (9 Oz.)
H: 7 ⅞" T: 3 ¼"
B: 2 ¾" M: 2 ⅞"
4 Dz.



H2317
Wine (11 ¾ Oz.)
H: 8 ⅝" T: 2 ⅜"
B: 3" M: 3 ⅛"
4 Dz.



H2318
Wine (15 Oz.)
H: 9 ¼" T: 2 ½"
B: 3" M: 3 ¼"
4 Dz.

Tall sides and sheer rims suit nearly any wine.

TECHNOLOGY & MATERIAL

ARMORIM
HIGH RIM RESISTANCE





H8466
Brio Flute (3 Oz.)
H: 6 1/16" T: 1 7/8"
B: 2 1/8" M: 2 1/4"
2 Dz.



J1478
Brio Flute (5 1/4 Oz.)
H: 7 7/8" T: 2 1/8"
B: 2 3/8" M: 2 5/8"
2 Dz.



L8941
Brio Coupe (7 Oz.)
H: 7 5/8" T: 2 7/8"
B: 3" M: 3 1/4"
2 Dz.

Fine rims, sparkling bodies and flavor enhancing teardrop shapes at a great value.

TECHNOLOGY & MATERIAL

ARMORIM
HIGH RIM RESISTANCE



For Tumblers See Page 53



★ ★ ★ ★ ★
STEMWARE

ARCOROC EXCALIBUR



The workhorse of glassware.

More resistant to mechanical and thermal shock than regular annealed glass—up to 5X more resistant to breakage.



71084
Tall Wine (8 ½ Oz.)
H: 6 13/16" T: 2 3/8"
B: 2 3/4" M: 2 15/16"
3 Dz.



71083
Tall Wine (10 ½ Oz.)
H: 7 1/4" T: 2 7/8"
B: 2 3/4" M: 3 3/16"
3 Dz.



8 oz.
6 oz.

D1CM5312
Vin with pour line (12 Oz.)
H: 7 1/2" T: 3" B: 3" M: 3 3/8"
2 Dz.
6 Oz. Bottom of Vin
8 Oz. Top of Vin
Approximate Pour Lines



71086
Flute (5 ¾ Oz.)
H: 7 ¾" T: 2"
B: 2 1/2" M: 2 1/2"
3 Dz.



71080
Grand Savoie (12 Oz.)
H: 7 1/2" T: 3"
B: 3" M: 3 3/8"
2 Dz.



71075
Grand Ballon (13 Oz.)
H: 6 7/8" T: 3 1/8"
B: 3" M: 3 3/8"
2 Dz.



P0776
Breeze (11 ¾ Oz.)
H: 8" T: 2 3/8"
B: 3" M: 3 1/8"
2 Dz.



P0777
Breeze (15 ¾ Oz.)
H: 8 5/8" T: 2 3/4"
B: 3" M: 3 1/2"
2 Dz.

For Tumblers See Page 63

TECHNOLOGY & MATERIAL



STEMWARE ★★



12926
Iced Tea (16 ½ Oz.)
H: 7 5/8" T: 2 13/16"
B: 3" M: 3 1/4"
2 Dz.



04757
All Purpose Goblet (14 Oz.)
H: 6 3/4" T: 2 7/8"
B: 3" M: 3 3/16"
2 Dz.



71076
All Purpose Goblet (11 Oz.)
H: 6 1/4" T: 2 1/2"
B: 3" M: 3 1/16"
3 Dz.



71078
Banquet Goblet (11 ½ Oz.)
H: 5 1/4" T: 3"
B: 2 7/8" M: 3 5/16"
3 Dz.



71093
Petite Cuvée (13 Oz.)
H: 7" T: 2 3/4"
B: 3" M: 3 3/16"
2 Dz.



71081
Grand Cuvée (13 Oz.)
H: 8 1/8" T: 2 3/4"
B: 3" M: 3 3/16"
2 Dz.



71079
Brandy (12 Oz.)
H: 5 1/4" T: 2"
B: 2 1/8" M: 2 3/8"
2 Dz.



71092
Footed Hi Ball (8 Oz.)
H: 5 1/4" T: 2 3/4"
B: 2 5/8" M: 2 3/4"
3 Dz.

For Tumblers See Page 63

TECHNOLOGY & MATERIAL





L0371
Coupe Cocktail (8 Oz.)
H: 5 5/8" T: 4 3/8"
B: 3" M: 4 3/8"
2 Dz.



D2024
Cocktail (7 1/2 Oz.)
H: 6 3/4" T: 4 1/2"
B: 3" M: 4 1/2"
1 Dz.



09232
Cocktail (non-tempered) (7 1/2 Oz.)
H: 6 3/4" T: 4 1/2"
B: 3" M: 4 1/2"
1 Dz.



79320
Cocktail (non-tempered) (10 Oz.)
H: 7 7/16" T: 4 3/4"
B: 3" M: 4 3/4"
1 Dz.



00213
Cocktail (10 Oz.)
H: 7 7/16" T: 4 3/4"
B: 3" M: 4 3/4"
1 Dz.



07395
Ballon Goblet (11 1/2 Oz.)
H: 5 3/4" T: 2 7/8"
B: 2 3/4" M: 3 1/4"
3 Dz.



06942
Super Savoie (12 Oz.)
H: 7 1/8" T: 3"
B: 3 1/16" M: 3 3/16"
2 Dz.

For Tumblers See Page 63

TECHNOLOGY & MATERIAL





● **E3559**
Stacking Goblet (6 ½ Oz.)
H: 4 ¼" T: 2 ⅝"
B: 2 ¼" M: 2 7/8"
4 Dz.



● **E3562**
Stacking Goblet (8 ½ Oz.)
H: 4 5/8" T: 2 3/4"
B: 2 ½" M: 3 1/8"
4 Dz.

★
★
★
STEMWARE

TECHNOLOGY & MATERIAL





57286
Wine (8 Oz.)
H: 5 3/8" T: 3"
B: 2 7/8" M: 3"
4 Dz.



57070
Wine (10 1/2 Oz.)
H: 5 3/4" T: 3 1/8"
B: 2 7/8" M: 3 1/8"
4 Dz.

For Tumblers See Page 62

TECHNOLOGY & MATERIAL





★
★
★
STEMWARE



37264
Cordial (2 Oz.)
H: 4 1/2" T: 1 5/8"
B: 1 7/8" M: 1 7/8"
4 Dz.



37439
Wine (4 Oz.)
H: 5 1/4" T: 2"
B: 2 1/8" M: 2 3/8"
4 Dz.



37413
Wine (6 Oz.)
H: 6" T: 2 1/2"
B: 2 1/2" M: 2 3/4"
4 Dz.



37405
Wine (8 1/4 Oz.)
H: 6 1/2" T: 2 5/8"
B: 2 3/4" M: 3"
4 Dz.



50143
Goblet (10 1/2 Oz.)
H: 7 1/8" T: 2 7/8"
B: 3" M: 3 1/4"
3 Dz.



56416
Flute (4 1/2 Oz.)
H: 7" T: 1 5/8"
B: 2 1/4" M: 2 1/4"
4 Dz.



37298
Flute (5 3/4 Oz.)
H: 7" T: 2"
B: 2 1/4" M: 2 1/4"
4 Dz.



37652
Coupe Cocktail (5 1/4 Oz.)
H: 4 3/4" T: 3 3/8"
B: 2 3/4" M: 3 1/2"
4 Dz.



H0652
Tall Wine (12 Oz.)
H: 7 15/16" T: 2 1/2"
B: 2 1/16" M: 3 3/16"
2 Dz.



H0654
Tall Wine (16 Oz.)
H: 8 3/4" T: 2 3/4"
B: 3 1/16" M: 3 7/16"
2 Dz.



H0655
Tall Wine (19 Oz.)
H: 9 1/16" T: 2 15/16"
B: 3 1/16" M: 3 1/16"
2 Dz.



H0656
Flute (5 3/4 Oz.)
H: 7 7/8" T: 1 15/16"
B: 2 5/8" M: 2 3/16"
2 Dz.



★
★
★
STEMWARE



N0834
 Macaron Rocks (13 ½ Oz.)
 H: 4" T: 2 ¾"
 B: 2" M: 3 ½"
 2 Dz.



U1032
 Open Up Warm Tumbler (10 Oz.)
 H: 3 ¾" T: 2 ¾"
 B: 1 7/8" M: 3 7/8"
 2 Dz.



U1033
 Open Up Old Fashioned (13 ½ Oz.)
 H: 3 ¾" T: 2 ¾"
 B: 1 7/8" M: 3 5/8"
 2 Dz.

★ ★ ★ ★ ★
 TUMBLERS & BARWARE



L5757
 Rocks (8 ½ Oz.)
 H: 3 ¼" T: 2 ¾"
 B: 2 ½" M: 3 ½"
 1 Dz.



L5758
 Rocks (10 ½ Oz.)
 H: 3 ½" T: 3"
 B: 2 ¼" M: 3 ¾"
 1 Dz.



L5756
 Double Old Fashioned (13 ½ Oz.)
 H: 3 5/8" T: 3"
 B: 2 3/8" M: 3 3/8"
 1 Dz.



L5754
 Hi Ball (11 ½ Oz.)
 H: 5 ¾" T: 2 ½"
 B: 2" M: 2 5/8"
 1 Dz.



L5755
 Cooler (16 Oz.)
 H: 6 3/8" T: 2 ½"
 B: 2 ½" M: 3"
 1 Dz.

TECHNOLOGY & MATERIAL

For Stemware See Page 13, 25 and 29



CABERNET SHEER

KRYSTA®

C&S
Chef & Sommelier
 - FRANCE -



TUMBLERS & BARWARE



L2369
 Beverage (15 Oz.)
 H: 6 1/2" T: 2 3/8"
 B: 2 1/4" M: 2 3/4"
 2 Dz.



G3674
 Beverage (11 1/2 Oz.)
 H: 4 3/4" T: 2 1/2"
 B: 2 1/8" M: 2 1/2"
 2 Dz.



G3658
 Hi Ball (7 3/4 Oz.)
 H: 4 3/8" T: 2 1/4"
 B: 1 7/8" M: 2 3/8"
 2 Dz.



L2370
 Double Old Fashioned (12 1/2 Oz.)
 H: 3 1/2" T: 3 3/8"
 B: 2 7/8" M: 3 1/2"
 2 Dz.



G3666
 Rocks (10 1/2 Oz.)
 H: 3 1/4" T: 3 1/8"
 B: 2 5/8" M: 3 5/16"
 2 Dz.



G3659
 Rocks (7 Oz.)
 H: 2 3/4" T: 2 3/4"
 B: 2 3/8" M: 2 3/4"
 2 Dz.

TECHNOLOGY & MATERIAL



For Stemware See Page 17



L8507
Tumbler (12 ¾ Oz.)
H: 4" T: 2 ¾"
B: 3 ½" M: 3 ½"
2 Dz.



L8675
Tumbler (12 ¾ Oz.)
H: 4 7/8" T: 2 3/8"
B: 3" M: 3"
2 Dz.



L8508
Tumbler (15 ¼ Oz.)
H: 5 ½" T: 2 ½"
B: 3 ¼" M: 3 ¼"
2 Dz.



Unique shapes offer a contemporary and modern experience.



★ ★ ★ ★ ★ TUMBLERS & BARWARE



Modern angular shapes with sheer rim perfectly complement the Cabernet and Sublym collections.

★
 ★
 ★
 ★
 ★
 TUMBLERS & BARWARE



G3367
 Old Fashioned (11 ¾ Oz.)
 H: 3 ¼" T: 2 7/8"
 B: 2 ½" M: 3 ½"
 2 Dz.



G3368
 Hi Ball (12 ¾ Oz.)
 H: 4 ¼" T: 2 ½"
 B: 1 7/8" M: 3 ¼"
 2 Dz.



L8110
 Beverage (13 ½ Oz.)
 H: 5 ¾" T: 2 ½"
 B: 2" M: 3"
 2 Dz.



L2356
 Hi Ball (15 ½ Oz.)
 H: 6 ½" T: 2 ¾"
 B: 1 7/8" M: 2 ¾"
 2 Dz.

TECHNOLOGY & MATERIAL





G0036
 Rocks (9 Oz.)
 H: 3 1/2" T: 2 1/4"
 B: 1 5/8" M: 2 3/4"
 2 Dz.



G3322
 Double Old Fashioned (12 Oz.)
 H: 4" T: 2 5/8"
 B: 1 7/8" M: 3"
 2 Dz.



G3323
 Beverage (14 3/4 Oz.)
 H: 4 1/4" T: 2 5/8"
 B: 1 7/8" M: 3 1/4"
 2 Dz.



L8677
 Hi Ball (13 1/2 Oz.)
 H: 5 1/8" T: 2 1/4"
 B: 1 7/8" M: 3"
 2 Dz.



N6675
 Arpege Blue Double Old Fashioned (12 Oz.)
 H: 4" T: 2 5/8"
 B: 1 7/8" M: 3"
 2 Dz.



L6767
 Arpege Double Old Fashioned (12 Oz.)
 H: 4" T: 2 5/8"
 B: 1 7/8" M: 3"
 2 Dz.



L6772
 Arpege Double Old Fashioned (12 Oz.)
 H: 4" T: 2 5/8"
 B: 1 7/8" M: 3"
 2 Dz.

Multipurpose glassware for wine, cocktails or beverage service.
 Complement with Cabernet Stemware.

T E C H N O L O G Y & M A T E R I A L



★ ★ ★ ★ ★ T U M B L E R S & B A R W A R E

MACASSAR



Striking panel cuts bring a traditional touch to whiskey and cocktails with exceptional clarity.



Q4337
Rocks (10 ¾ Oz.)
H: 3 7/8" T: 3 ¾"
B: 2 7/8" M: 3 ¾"
1 Dz.



Q4340
Hi Ball (12 Oz.)
H: 5" T: 3 ¼"
B: 2 ½" M: 3 ¼"
1 Dz.

ARCHITECTE



Geometric art and sculpture in glass form. This paneled glass collection brings a sophisticated touch to your beverage service.



Q4353
Rocks (10 ¾ Oz.)
H: 3 7/8" T: 3 ½"
B: 2 ¾" M: 3 ½"
1 Dz.



Q4357
Hi Ball (12 Oz.)
H: 5" T: 3 3/8"
B: 2 ¼" M: 3 3/8"
1 Dz.

TECHNOLOGY & MATERIAL



TUMBLERS & BARWARE

RENDEZ - VOUS



Q4354
 Rocks (10 ¾ Oz.)
 H: 3 ¾" T: 3 ½"
 B: 3" M: 3 ½"
 1 Dz.



Q4358
 Hi Ball (12 Oz.)
 H: 5 ⅞" T: 3 ¼"
 B: 2 ½" M: 3 ¼"
 1 Dz.

Contemporary multifaceted panel designs with outstanding brightness for beverage presentations.



TECHNOLOGY & MATERIAL



★ ★ ★ ★ ★ TUMBLERS & BARWARE



N5994
Hi Ball (13 ½ Oz.)
H: 4 ¾" T: 2 ½"
B: 2" M: 3 ½"
2 Dz.



N5995
Double Old Fashioned (11 ¾ Oz.)
H: 3 ¼" T: 3"
B: 2 ¼" M: 3 ¾"
2 Dz.

MALEA **ARCOROC**



H4623
Rocks (10 Oz.)
H: 4 ⅛" T: 2 ½"
B: 2" M: 3"
2 Dz.



H4531
Hi Ball (12 Oz.)
H: 5" T: 2 ¾"
B: 1 ¾" M: 3"
2 Dz.

TECHNOLOGY & MATERIAL



This tumbler collection features a heavy sham, straight wall and sheer rim.

With a variety of pieces in the collection, Precision offers an elevated look while at a valued pricepoint.



P8496
Rocks (7 1/2 Oz.)
H: 3 3/8" T: 2 7/8"
B: 2 3/8" M: 2 7/8"
1 Dz.



P8500
Rocks (10 1/2 Oz.)
H: 3 1/4" T: 3 1/4"
B: 3" M: 3 1/4"
1 Dz.



P8495
Double Old Fashioned (14 Oz.)
H: 4" T: 3 1/4"
B: 3" M: 3 1/4"
1 Dz.



P8494
Collins/Beverage (13 Oz.)
H: 5 3/8" T: 2 3/4"
B: 2 3/8" M: 2 3/4"
1 Dz.



P8499
Cooler (16 Oz.)
H: 6 1/8" T: 2 7/8"
B: 2 1/2" M: 2 7/8"
1 Dz.

TECHNOLOGY & MATERIAL



Slightly twisted square base and clean lines with optimal strength.



E1515
Rocks (9 Oz.)
H: 3 1/2" T: 3 5/8"
B: 2 3/4" M: 3 5/8"
4 Dz.



E1514
Double Old Fashioned (12 1/2 Oz.)
H: 3 3/4" T: 4"
B: 3" M: 4"
4 Dz.



E1513
Beverage (12 Oz.)
H: 5" T: 3 1/2"
B: 2 1/2" M: 3 1/2"
4 Dz.



H0736
Cooler (16 Oz.)
H: 5 3/4" T: 3 3/4"
B: 2 3/4" M: 3 3/4"
4 Dz.

TECHNOLOGY & MATERIAL





The soft, delicate panels of the Arcadie collection offer a sense of simplicity.
The versatility of the line allows for easy cross functional service and the nestable design adds for easy space saving.

NEW

ARCADIE

FULLY TEMPERED

ARCOROC



Q2233
Rocks (3 Oz.)
H: 2 1/2" T: 2 7/16"
B: 1 1/4" M: 2 7/16"
2 Dz.



Q2234
Rocks (5 1/4 Oz.)
H: 3" T: 3"
B: 1 13/16" M: 3"
2 Dz.



Q2967
Rocks (8 Oz.)
H: 3 3/8" T: 3 5/16"
B: 2" M: 3 3/16"
2 Dz.



Q2750
Double Old Fashioned (11 3/4 Oz.)
H: 3 7/8" T: 3 3/4"
B: 2 3/8" M: 3 3/4"
2 Dz.



Q2751
Hi Ball (13 1/2 Oz.)
H: 5" T: 3 11/16"
B: 2 1/4" M: 3 11/16"
2 Dz.



TUMBLERS & BARWARE

TECHNOLOGY & MATERIAL



ARCOROC GOTHAM



Our classic, multi-faceted design adds a splash of European café culture.



J4094
Rocks (4 1/2 Oz.)
H: 3 1/4" T: 2 3/4"
B: 1 3/4" M: 2 3/4"
3 Dz.



J4096
Rocks (8 Oz.)
H: 3 1/2" T: 3 1/4"
B: 2 1/4" M: 3 1/2"
3 Dz.



J4097
Rocks (9 Oz.)
H: 3 1/2" T: 3 1/4"
B: 2 1/4" M: 3 5/8"
3 Dz.



J4099
Double Old Fashioned (12 Oz.)
H: 3 3/4" T: 3 1/2"
B: 2 1/2" M: 3 1/2"
3 Dz.



J4101
Beverage (10 Oz.)
H: 4 3/4" T: 3"
B: 2 1/4" M: 3 1/8"
3 Dz.



J4102
Beverage (12 Oz.)
H: 4 3/4" T: 3 1/4"
B: 2 1/2" M: 3 1/4"
3 Dz.



J4103
Beverage (14 Oz.)
H: 5 1/8" T: 3 1/2"
B: 2 1/2" M: 3 1/2"
3 Dz.



J4104
Cooler (16 Oz.)
H: 6 1/4" T: 3 1/2"
B: 2 1/2" M: 3 1/2"
3 Dz.

TECHNOLOGY & MATERIAL



★ ★ ★
TUMBLERS & BARWARE

ARCOROC STACK UP



Superior stackability makes this a go-to choice for space savers.



H3858
Rocks (7 Oz.)
H: 3 1/8" T: 3 1/4"
B: 2 3/8" M: 3 1/4"
1 Dz.



J0317
Old Fashioned (8 3/4 Oz.)
H: 3 5/8" T: 3 3/8"
B: 2 1/4" M: 3 3/8"
2 Dz.



H3032
Old Fashioned (10 1/2 Oz.)
H: 3 5/8" T: 3 5/8"
B: 2 1/2" M: 3 5/8"
1 Dz.



H5169
Double Old Fashioned (12 Oz.)
H: 3 7/8" T: 3 5/8"
B: 2 3/4" M: 3 5/8"
1 Dz.



H3839
Hi Ball (10 Oz.)
H: 5 3/8" T: 2 7/8"
B: 2 1/8" M: 2 7/8"
1 Dz.



H7763
Hi Ball (11 3/4 Oz.)
H: 5 1/2" T: 3 1/8"
B: 2 1/8" M: 3 1/8"
2 Dz.



H3856
Beverage (14 Oz.)
H: 5 5/8" T: 3 1/4"
B: 2 1/4" M: 3 1/4"
1 Dz.



H3089
Cooler (16 Oz.)
H: 5 3/4" T: 3 3/8"
B: 2 3/8" M: 3 3/8"
1 Dz.



H3008
Cooler (21 Oz.)
H: 6 3/8" T: 3 3/8"
B: 2 3/8" M: 3 5/8"
1 Dz.

TECHNOLOGY & MATERIAL



ARCOROC ARTIC | FULLY TEMPERED



53664
 Juice (6 Oz.)
 H: 3 3/4" T: 2 1/4"
 B: 1 5/8" M: 2 1/4"
 4 Dz.

75926
 Hi Ball (8 3/4 Oz.)
 H: 4 3/8" T: 2 5/8"
 B: 2" M: 2 5/8"
 4 Dz.



D6315
 Hi Ball (10 1/2 Oz.)
 H: 5" T: 2 3/4"
 B: 2" M: 2 3/4"
 4 Dz.

57069
 Beverage (12 1/2 Oz.)
 H: 5 3/8" T: 2 7/8"
 B: 2 1/4" M: 2 7/8"
 4 Dz.

For Stemware See Page 43

ARCOROC NORVEGE | FULLY TEMPERED



60024
 Old Fashioned (6 1/2 Oz.)
 H: 3 1/2" T: 2 3/4"
 B: 2 1/8" M: 2 3/4"
 6 Dz.



61697
 Old Fashioned (8 1/2 Oz.)
 H: 3 5/8" T: 3"
 B: 2 1/4" M: 3"
 6 Dz.



60440
 Hi Ball (9 1/2 Oz.)
 H: 4 1/2" T: 2 3/4"
 B: 2" M: 2 3/4"
 6 Dz.



61698
 Beverage (10 3/4 Oz.)
 H: 5" T: 2 7/8"
 B: 2 1/2" M: 2 7/8"
 6 Dz.

TECHNOLOGY & MATERIAL



★ ★ ★ TUMBLERS & BARWARE



20875
Old Fashioned (7 Oz.)
H: 3 1/6" T: 3"
B: 2 1/8" M: 3"
3 Dz.



20874
Old Fashioned (9 Oz.)
H: 3 1/4" T: 3 1/4"
B: 2 3/16" M: 3 1/4"
3 Dz.



20873
Old Fashioned (10 1/2 Oz.)
H: 3 1/2" T: 3 7/16"
B: 2 1/2" M: 3 7/16"
3 Dz.



20871
Hi Ball (6 Oz.)
H: 4" T: 2 1/2"
B: 1 3/4" M: 2 1/2"
3 Dz.



20869
Hi Ball (8 Oz.)
H: 4 9/16" T: 2 9/16"
B: 1 7/8" M: 2 9/16"
3 Dz.



20868
Hi Ball (9 Oz.)
H: 4 3/4" T: 2 11/16"
B: 1 7/8" M: 2 11/16"
3 Dz.



20867
Hi Ball (10 1/2 Oz.)
H: 5 1/16" T: 2 13/16"
B: 2" M: 2 13/16"
3 Dz.



20866
Hi Ball (11 Oz.)
H: 5 1/4" T: 2 7/8"
B: 2" M: 2 7/8"
3 Dz.



20865
Beverage (12 1/2 Oz.)
H: 5 11/16" T: 2 7/8"
B: 2" M: 2 7/8"
3 Dz.



20864
Beverage (16 Oz.)
H: 6" T: 3 1/8"
B: 2 1/8" M: 3 1/8"
3 Dz.

For Stemware See Page 39

TECHNOLOGY & MATERIAL



ARCOROC GRANITE

FULLY TEMPERED



J2614
Tall Rocks (9 Oz.)
H: 3 7/8" T: 3 3/8"
B: 2 3/8" M: 3 3/8"
4 Dz.



J2605
Beverage (10 1/2 Oz.)
H: 5 1/2" T: 2 7/8"
B: 2 3/16" M: 2 7/8"
2 Dz.



43279
Cooler (12 Oz.)
H: 4 7/8" T: 3 1/4"
B: 2 5/8" M: 3 1/4"
3 Dz.

J2603
Cooler (14 Oz.)
H: 5 1/8" T: 3 1/2"
B: 2 3/4" M: 3 1/2"
2 Dz.



J2610
Rocks (5 1/4 Oz.)
H: 3" T: 2 3/4"
B: 2 3/16" M: 2 3/4"
4 Dz.

J2611
Rocks (7 Oz.)
H: 3 1/4" T: 3 3/8"
B: 2 1/4" M: 3 1/8"
2 Dz.

L7844
Double Old Fashioned (11 3/4 Oz.)
H: 4 1/4" T: 3 5/8"
B: 2 3/4" M: 3 5/8"
2 Dz.

ARCOROC PRINCESA

FULLY TEMPERED



J4168
Old Fashioned (10 1/4 Oz.)
H: 3 1/16" T: 3 1/8"
B: 2 15/16" M: 3 1/8"
3 Dz.



J4170
Hi Ball (8 Oz.)
H: 4 5/8" T: 2 1/2"
B: 2 5/16" M: 2 1/2"
4 Dz.



42440
Hi Ball (10 Oz.)
H: 4 15/16" T: 2 9/16"
B: 2 5/16" M: 2 9/16"
4 Dz.

TECHNOLOGY & MATERIAL



★ ★ ★ TUMBLERS & BARWARE



Intricately cut facets create a vintage look in four distinct fully tempered designs for added strength and durability.



L7339
Rocks (9 ¼ Oz.)
H: 3 ¼" T: 3 ¼"
B: 2 ½" M: 3 ¼"
2 Dz.



L7334
Double Old Fashioned (12 ¾ Oz.)
H: 3 7/8" T: 3 7/16"
B: 2 7/8" M: 3 7/16"
2 Dz.



L7335
Hi Ball (11 ¾ Oz.)
H: 5 5/8" T: 2 7/16"
B: 2 ¼" M: 2 7/8"
2 Dz.



L7340
Hi Ball (16 Oz.)
H: 5 5/8" T: 3 ½"
B: 2 5/8" M: 3 ½"
2 Dz.

TECHNOLOGY & MATERIAL





A sleek and sophisticated barware line that features a slimming perspective and thin base.



J4764
Rocks (7 1/2 Oz.)
H: 2 3/4" T: 3 1/4"
B: 2 7/8" M: 3 1/4"
6 Pcs.



15012
Hi Ball (10 1/2 Oz.)
H: 6 1/2" T: 2 3/8"
B: 2 1/8" M: 2 1/4"
2 Dz.

NEW



Q1774
Collins (13 Oz.)
H: 6 1/8" T: 2 3/4"
B: 2 1/4" M: 2 3/4"
1 Dz.



J3510
Rocks (12 1/2 Oz.)
H: 3 1/2" T: 3 1/4"
B: 2 7/8" M: 3 1/4"
6 Pcs.



N8981*
Blue Rocks (12 1/2 Oz.)
H: 3 1/2" T: 3 1/4"
B: 2 7/8" M: 3 1/4"
6 Pcs.



N8901*
Grey Rocks (12 1/2 Oz.)
H: 3 1/2" T: 3 1/4"
B: 2 7/8" M: 3 1/4"
6 Pcs.

NEW



L6500
Beverage (17 Oz.)
H: 4 7/8" T: 3 1/2"
B: 2 3/4" M: 3 5/8"
2 Dz.



N8982*
Blue Beverage (17 Oz.)
H: 4 7/8" T: 3 1/2"
B: 2 3/4" M: 3 5/8"
6 Pcs.



N9029*
Grey Beverage (17 Oz.)
H: 4 7/8" T: 3 1/2"
B: 2 3/4" M: 3 5/8"
6 Pcs.



Q6480
Cooler (20 3/4 Oz.)
H: 5 3/4" T: 3 1/4"
B: 3 1/4" M: 3 1/4"
1 Dz.

TECHNOLOGY & MATERIAL



*Color is applied via spray, sprayed glassware can last up to 1,000 washes.

ARCOROC BE BOP | FULLY TEMPERED



A new twist on the tin can for Bloody Mary's, Mojitos and cocktails alike with a guaranteed wow factor.



L8687
Old Fashioned (11 Oz.)
H: 3 1/4" T: 3 1/4"
B: 3 1/4" M: 3 1/4"
2 Dz.



L8688
Hi Ball (11 3/4 Oz.)
H: 5 3/4" T: 2 3/4"
B: 2 3/8" M: 2 3/4"
2 Dz.



L6942
Mug (3 1/4 Oz.)
H: 2 7/8" T: 2 1/8"
B: 2 1/8" M: 3"
2 Dz.



L6943
Mug (8 1/4 Oz.)
H: 3 1/2" T: 3 1/8"
B: 3" M: 4"
2 Dz.



L5275
Mug (11 Oz.)
H: 4 3/8" T: 3 1/8"
B: 3" M: 4 1/8"
2 Dz.

TECHNOLOGY & MATERIAL



— ARCOROC URBANE —



Long profile designs with slight curves and sturdy bottoms for increased durability at the bar.
Built with a stackable ledge for efficient space saving.



N0529
Whiskey/Shot (3 1/2 Oz.)
H: 3" T: 2 5/8"
B: 1 3/8" M: 2 5/8"
1 Dz.



N0523
Rocks (5 Oz.)
H: 3 1/4" T: 2 7/8"
B: 1 3/4" M: 2 7/8"
1 Dz.



N0530
Rocks (7 Oz.)
H: 3 3/8" T: 3 1/8"
B: 2" M: 3 1/8"
1 Dz.



N0531
Rocks (9 Oz.)
H: 3 7/8" T: 3 1/2"
B: 2 1/4" M: 3 1/2"
1 Dz.



N0512
Rocks (10 Oz.)
H: 4" T: 3 1/2"
B: 2 1/4" M: 3 1/2"
1 Dz.



N0524
Double Old Fashioned (12 Oz.)
H: 4 1/8" T: 3 3/4"
B: 2 3/8" M: 3 3/4"
1 Dz.



N0527
Double Old Fashioned (14 Oz.)
H: 4 1/4" T: 3 7/8"
B: 2 1/2" M: 3 7/8"
1 Dz.



N0513
Hi Ball (10 Oz.)
H: 6 1/4" T: 2 7/8"
B: 2" M: 2 7/8"
1 Dz.



N0521
Beverage (12 Oz.)
H: 6 1/4" T: 3"
B: 2 1/8" M: 3"
1 Dz.



N0528
Beverage (14 Oz.)
H: 6 3/8" T: 3 1/4"
B: 2 1/4" M: 3 1/4"
1 Dz.



N0520
Cooler (16 Oz.)
H: 7" T: 3 3/8"
B: 2 3/8" M: 3 3/8"
1 Dz.



N0526
Cooler (20 Oz.)
H: 7 1/4" T: 3 3/8"
B: 2 5/8" M: 3 5/8"
1 Dz.

TECHNOLOGY & MATERIAL

ARCOROC BRIXTON



An elegant cut glass design that will add sophistication and character to your beverage service.



P4188
Rocks (10 1/2 Oz.)
H: 3 3/4" T: 3 3/8"
B: 2 13/16" M: 3 3/8"
1 Dz.



P9067
Rocks (11 3/4 Oz.)
H: 4 3/8" T: 3 7/16"
B: 3" M: 3 7/16"
2 Dz.



P4187
Hi Ball (13 Oz.)
H: 6" T: 3"
B: 2 13/16" M: 3"
1 Dz.



P9411
Beverage (15 1/4 Oz.)
H: 6 1/2" T: 3 1/8"
B: 2 7/8" M: 3 1/8"
1 Dz.



ARCOROC BROADWAY



Strikingly beautiful cut glass adds stylish sophistication to your beverage service with a vintage touch.



L7253
Shot (2 Oz.)
H: 2 3/8" T: 1 7/8"
B: 1 1/8" M: 1 7/8"
2 Dz.



L7254
Rocks (10 1/2 Oz.)
H: 3 1/2" T: 3 3/8"
B: 3" M: 3 3/8"
2 Dz.



Q7932
Vintage Cocktail (8 1/4 Oz.)
H: 7 1/2" T: 3 1/2"
B: 2 9/16" M: 3 1/2"
2 Dz.
Available Q3



P8795
Cocktail (7 Oz.)
H: 6 1/8" T: 4 1/2"
B: 3" M: 4 1/2"
1 Dz.



P8796
Coupe Cocktail (8 Oz.)
H: 5 1/2" T: 4 1/2"
B: 3" M: 4 1/2"
1 Dz.



P8821
Gin Cocktail (19 1/2 Oz.)
H: 7 1/2" T: 4 1/4"
B: 3 1/4" M: 4 1/4"
1 Dz.



L7256
Hi Ball (9 1/4 Oz.)
H: 5 1/4" T: 2 3/8"
B: 2 1/4" M: 2 3/8"
2 Dz.



L7255
Hi Ball (12 Oz.)
H: 5 3/4" T: 3"
B: 2 1/2" M: 3"
2 Dz.



P1470
Beverage (15 Oz.)
H: 6 1/2" T: 3 1/8"
B: 2 3/4" M: 3 1/8"
2 Dz.

NEW

NEW

NEW

NEW

NEW





★ ★ ★ T U M B L E R S & B A R W A R E



79747
Old Fashioned (8 ½ Oz.)
H: 3 ½" T: 3 ½"
B: 2 ¾" M: 3 ½"
4 Dz.



E1907
Old Fashioned (10 ¾ Oz.)
H: 3 ⅞" T: 3 ¾"
B: 2 ½" M: 3 ¾"
4 Dz.



79736
Hi Ball (7 ½ Oz.)
H: 4 ¾" T: 2 ⅜"
B: 1 ¾" M: 2 ⅜"
4 Dz.



79728
Hi Ball (12 Oz.)
H: 5 ½" T: 3 ¼"
B: 2" M: 3 ¼"
4 Dz.



79698
Hi Ball (14 Oz.)
H: 5 ¾" T: 3 ⅝"
B: 2 ⅛" M: 3 ⅝"
4 Dz.



37159
Rocks (7 ½ Oz.)
H: 3 ½" T: 2 7/8"
B: 2 5/8" M: 2 1/16"
3 Dz.



53224
Old Fashioned (10 ½ Oz.)
H: 3 ½" T: 3 3/16"
B: 3" M: 3 3/16"
3 Dz.



53232
Double Old
Fashioned (14 Oz.)
H: 4 1/8" T: 3 3/8"
B: 3 1/8" M: 3 3/8"
3 Dz.



53205
Beverage (13 Oz.)
H: 5 ½" T: 2 7/8"
B: 2 ½" M: 2 7/8"
3 Dz.



53214
Cooler (16 Oz.)
H: 6 ¼" T: 2 7/8"
B: 2 ½" M: 2 7/8"
3 Dz.



C8832
Tumbler (9 Oz.)
H: 3 ¾" T: 2 ¼"
B: 1 ½" M: 2 ¾"
1 Dz.



P6284 Tumbler (12 Oz.)
H: 4 1/8" T: 2 ½"
B: 1 ¾" M: 3 1/8"
1 Dz.



C8303
Tumbler (15 Oz.)
H: 4 ¾" T: 2 5/8"
B: 1 7/8" M: 3 3/8"
1 Dz.



C8304
Tumbler (21 Oz.)
H: 5" T: 3"
B: 2 ¼" M: 3 ½"
1 Dz.



H4870 Flute (9 Oz.)
H: 5 5/8" T: 2 1/8"
B: 1 ½" M: 2 3/8"
1 Dz.



ARCOROC CABERNET



47346
Cordial (2 ½ Oz.)
H: 3 ½" T: 1 ½"
B: 1 ⅜" M: 1 ⅜"
4 Dz.



10007
Rocks (10 ½ Oz.)
H: 3 ¼" T: 3 ⅛"
B: 2 ¾" M: 3 ⅜"
3 Dz.



17198
Cooler (17 Oz.)
H: 5 ⅞" T: 2 ¾"
B: 2 ½" M: 3 ⅛"
1 Dz.

★ ★ ★ TUMBLERS & BARWARE





N5812
Hi Ball (11 ¾ Oz.)
H: 4 ¾" T: 2 ½"
B: 1 ⅝" M: 3"
2 Dz.



N5828
Cooler (17 Oz.)
H: 5 ¾" T: 2 ½"
B: 2" M: 3 ⅝"
2 Dz.



N5831
Rocks (10 ¾ Oz.)
H: 3 ¼" T: 3 ⅝"
B: 2 ¼" M: 3 ½"
2 Dz.



N5834
Cordial (2 Oz.)
H: 2 ½" T: 1 ⅞"
B: 1 ⅜" M: 1 ⅞"
4 Dz.

The elegant arched sides creates a glass that fits perfectly in all hands.



ARCOROC WINE BOTTOM TUMBLERS



The Art of Upcycling. The wine bottle design repurposed into a unique drinking vessel for a memorable beverage presentation. The distinctive base indentation gives a rustic appeal to this charming drinking glass.

WINE BOTTOM TUMBLERS **ARCOROC**



FK258
Green Tumbler (12 Oz.)
H: 4" T: 3"
B: 3" M: 3"
1 Dz.



FK259
Green Tumbler (16 Oz.)
H: 5 1/2" T: 3"
B: 3" M: 3"
1 Dz.



FJ063
Amber Tumbler (12 Oz.)
H: 4" T: 3"
B: 3" M: 3"
1 Dz.



FJ062
Amber Tumbler (16 Oz.)
H: 5 1/2" T: 3"
B: 3" M: 3"
1 Dz.



FJ060
Clear Tumbler (12 Oz.)
H: 4" T: 3"
B: 3" M: 3"
1 Dz.



FJ061
Clear Tumbler (16 Oz.)
H: 5 1/2" T: 3"
B: 3" M: 3"
1 Dz.



FL200
Clear Carafe (22 Oz.)
H: 7 1/2" W: 2 7/8"
B: 2 7/8" M: 3 1/4"
1 Dz.



FL203
Clear Carafe (30 Oz.)
H: 6" W: 4"
B: 3 3/4" M: 4 3/8"
16 Pcs.



TUMBLERS & BARWARE

Color variations may vary as a result of the product being made from recycled bottles.

— ARCOROC ISLANDE —



Islande's timeless design with straight sides and heavy shams is a barware essential.



40375
Cordial (2 ¼ Oz.)
H: 4 ½" T: 1 ½"
B: 1 ¾" M: 1 ½"
6 Dz.



J4238
Whiskey (3 ¼ Oz.)
H: 3 ⅞" T: 2"
B: 1 ⅞" M: 2"
2 Dz.



N6643
Juice (5 ¼ Oz.)
H: 4" T: 2 ⅞"
B: 2" M: 2 ⅞"
2 Dz.



J4241
Old Fashioned (7 Oz.)
H: 3 ¼" T: 2 ¾"
B: 2 ⅝" M: 2 ¾"
2 Dz.



12652
Old Fashioned (8 ½ Oz.)
H: 3 ⅞" T: 3 ⅞"
B: 3" M: 3 ⅞"
4 Dz.



J4239
Old Fashioned (10 Oz.)
H: 3 ⅞" T: 3 ⅞"
B: 3" M: 3 ⅞"
2 Dz.



N6640
Hi Ball (10 Oz.)
H: 5 ⅝" T: 2 ½"
B: 2 ¼" M: 2 ½"
2 Dz.



N6377
Double Old Fashioned (12 ¾ Oz.)
H: 3 ¾" T: 3 ½"
B: 3 ⅝" M: 3 ½"
2 Dz.



J4227
Hi Ball (11 Oz.)
H: 6 ½" T: 2 ¾"
B: 2 ⅞" M: 2 ¾"
2 Dz.



J4226
Collins (13 Oz.)
H: 6 ¾" T: 2 ½"
B: 2 ¼" M: 2 ½"
2 Dz.

NEW



Q7781
Hi Ball (15 ½ Oz.)
H: 6 ¼" T: 2 ⅞"
B: 2 ½" M: 2 ⅞"
1 Dz.

ARCOROC MOSCOW MULES



CA364
Antique Moscow Mule (16 Oz.)
H: 4" T: 3 3/8"
B: 2 1/4" M: 4 3/8"
1 Dz.



FK364
Copper Moscow Mule (16 Oz.)
H: 4" T: 3 3/8"
B: 2 1/4" M: 4 3/8"
1 Dz.



FK368
Copper Hammered Moscow Mule (16 Oz.)
H: 4" T: 3 3/8"
B: 2 1/4" M: 4 3/8"
1 Dz.



CHA36
Copper Hammered Antique Moscow Mule (16 Oz.)
H: 4" T: 3 3/8"
B: 2 1/4" M: 4 3/8"
1 Dz.



FK492
Black Moscow Mule (16 Oz.)
H: 4" T: 3 3/8"
B: 2 1/4" M: 4 3/8"
1 Dz.



FK493
Black Hammered Moscow Mule (16 Oz.)
H: 4" T: 3 3/8"
B: 2 1/4" M: 4 3/8"
1 Dz.



BHA49
Black Hammered Antique Moscow Mule (16 Oz.)
H: 4" T: 3 3/8"
B: 2 1/4" M: 4 3/8"
1 Dz.

- ★
- ★ Striking metallic presentations to serve your classic Moscow Mules, Ginger Beers and Beverages.
- ★ This vessel can also be used for your appetizer needs like french fries, zucchini sticks, and more.

TUMBLERS & BARWARE



The Working Glass is the valued to go glassware solution at an economy price point. This collection features an ergonomic paneled design for additional grip while handling, a rustic heavy rolled design and a lid for secure transport.

★ ★ ★
TUMBLERS & BARWARE



13297
Double Old Fashioned (14 Oz.)
H: 4" T: 3 5/8"
M: 3 5/8"
1 Dz.



53195
Cooler (21 Oz.)
H: 5 1/2" T: 3 13/16"
M: 3 13/16" B: 3 1/4"
1 Dz.



N2513
Lids ONLY (fits 13297, 53195)
48 Pcs.



L0996
Straw and Lid ONLY (fits 53195)
64 Pcs. (32 Lids and 32 Straws)



Classic jar designs perfect for serving unique cocktails, soft drinks, beer or desserts! Versatile vessels with a rustic aesthetic.

Lids are perfect for your off premise needs!



FK209
Mason Jar with Handle (4 ¾ Oz.)
H: 3 ⅜" T: 1 ¾"
B: 1 ¾" M: 2 ⅞"
1 Dz.



FK206
Mason Jar Non-Handle (15 ¼ Oz.)
H: 5 ¼" T: 2 ⅝"
B: 2 ½" M: 3"
1 Dz.



FK203
Mason Jar with Handle (16 ½ Oz.)
H: 5 ¼" T: 2 ⅝"
B: 2 ⅝" M: 4 ⅞"
1 Dz.



FL012
Mason Jar Lid (fits FK206, FK203)
L: 2 ⅞" W: 2 ⅞"
H: ⅞"
1 Dz.



FL013
Mason Jar Lid (fits FK209)
L: 2" W: 2"
H: ½"
1 Dz.



FK213
Milk Jar (6 ¾ Oz.)
H: 4 ¾" T: 1 ¼"
B: 2 ¾" M: 2 ¾"
2 Dz.



FK212
Milk Jar (10 ¾ Oz.)
H: 6 ¼" T: 1 ¼"
B: 2 ½" M: 2 ½"
1 Dz.



FL014
Milk Jar Lid (fits FK213, FK212)
L: 2" W: 2"
H: ½"
1 Dz.



FL108
Milk Jar Lid with hole
(fits FK213, FK212)
L: 2" W: 2"
H: ½"
1 Dz.

Repurpose these nostalgic classic glasses for unique cocktail or to bottle your fresh juices!
Lids are perfect for your off premise needs!



ARCOROC COOLER



D0130
Cooler (14 1/2 Oz.)
H: 6 3/8" T: 2 3/8"
B: 2" M: 2 7/8"
2 Dz.



E5458
Can Cooler (16 Oz.)
H: 5 1/4" T: 2 3/8"
B: 2 1/2" M: 3"
3 Dz.



L4865
Tall Can Cooler (16 Oz.)
H: 6 1/2" T: 2 1/4"
B: 2 1/2" M: 2 5/8"
2 Dz.



★
★
★
TUMBLERS & BARWARE

ROOM TUMBLERS **ARCOROC**



43745
Room Tumbler (11 Oz.)
H: 3 1/2" T: 3 1/8"
B: 3" M: 3 1/8"
3 Dz.



76495
Sterling Rocks (9 3/4 Oz.)
H: 3 5/16" T: 3 3/16"
B: 3 1/8" M: 3 3/16"
3 Dz.



43746
Room Tumbler (8 Oz.)
H: 3 5/8" T: 2 3/4"
B: 2 5/8" M: 2 3/4"
6 Dz.



29811
Room Tumbler (8 3/4 Oz.)
H: 3 5/16" T: 3"
B: 2 3/4" M: 3"
3 Dz.



E1908
Petale Hi Ball (8 3/4 Oz.)
H: 4 1/16" T: 3"
B: 2" M: 3"
4 Dz.

MONROE **ARCOROC**



ES002
Stemless Cocktail (8 Oz.)
H: 3 1/2" T: 3 3/4"
B: 2" M: 3 3/4"
1 Dz.



ES001
Stemless Cocktail (10 Oz.)
H: 3 3/4" T: 4 1/8"
B: 2 1/8" M: 4 1/8"
1 Dz.

Vertical cut design refracts light and provides texture. Wide rims increase garnish space.

TECHNOLOGY & MATERIAL



★
★
★
TUMBLERS & BARWARE



N6815
 Champagne Coupe (10 Oz.)
 H: 6 3/4" T: 4 3/8"
 B: 2 7/8" M: 4 5/8"
 1 Dz.

NEW



Q3702
 Nick and Nora Cocktail (5 1/4 Oz.)
 H: 5 5/8" T: 2 3/4"
 B: 2 3/8" M: 2 3/4"
 2 Dz.



L5641
 Sequence Coupe Cocktail (7 3/4 Oz.)
 H: 5 7/8" T: 4 3/8"
 B: 3" M: 4 3/8"
 1 Dz.



L3678
 Sublym Coupe Cocktail (8 Oz.)
 H: 7 1/8" T: 4 1/2"
 B: 3" M: 4 1/2"
 2 Dz.



N6887
 Cabernet Cocktail (7 1/2 Oz.)
 H: 6 3/4" T: 4 1/2"
 B: 3" M: 4 1/2"
 1 Dz.



N6831
 Cabernet Cocktail (10 Oz.)
 H: 7 1/2" T: 4 3/4"
 B: 3" M: 4 3/4"
 1 Dz.

★ ★ ★ ★ ★ MARTINIS • COUPES

TECHNOLOGY & MATERIAL





•71093
Excilibur Petite Cuvee (13 Oz.)
H: 7" T: 2 3/4"
B: 3" M: 3 5/16"
2 Dz.



•71081
Excilibur Grand Cuvee (13 Oz.)
H: 8 1/8" T: 2 3/4"
B: 3" M: 3 5/16"
2 Dz.



•E6128
Outdoor Perfect Hurricane (14 3/4 Oz.)
H: 9 1/8" T: 2 7/8"
B: 3" M: 2 7/8"
3 Dz.



C2172
Hurricane (15 Oz.)
H: 8 1/4" T: 3 1/8"
B: 3" M: 3 1/8"
2 Dz.



•E6127
Outdoor Perfect Margarita (12 Oz.)
H: 6 7/8" T: 4 7/8"
B: 3 1/4" M: 4 3/4"
2 Dz.



•22760
Excilibur Cocktail (5 Oz.)
H: 6" T: 3 3/4"
B: 2 3/4" M: 3 3/4"
3 Dz.

NEW



P8795
Broadway Cocktail (7 Oz.)
H: 6 1/8" T: 4 1/2"
B: 3" M: 4 1/2"
1 Dz.



•D2024
Excilibur Cocktail (7 1/2 Oz.)
H: 6 3/4" T: 4 1/2"
B: 3" M: 4 1/2"
1 Dz.

TECHNOLOGY & MATERIAL



ARCOROC MARTINIS • COUPES



09232
 Excalibur Cocktail (non-tempered) (7 ½ Oz.)
 H: 6 ¾" T: 4 ½"
 B: 3" M: 4 ½"
 1 Dz.



00213
 Excalibur Cocktail (10 Oz.)
 H: 7 ⅞" T: 4 ¾"
 B: 3" M: 4 ¾"
 1 Dz.



79320
 Excalibur Cocktail (non-tempered) (10 Oz.)
 H: 7 ⅞" T: 4 ¾"
 B: 3" M: 4 ¾"
 1 Dz.



E6132
 Outdoor Perfect Cocktail (10 Oz.)
 H: 7 ⅞" T: 4 ¾"
 B: 3 ¼" M: 4 ⅝"
 2 Dz.

NEW



Q7932
 Vintage Cocktail (8 ¼ Oz.)
 H: 7 ½" T: 3 ½"
 B: 3" M: 3 ½"
 1 Dz.

NEW



P8821
 Broadway Gin Cocktail (19 ½ Oz.)
 H: 7 ½" T: 4 ¼"
 B: 3 ¼" M: 4 ¼"
 1 Dz.

NEW



P8064
 Gin Cocktail (20 ¾ oz)
 H: 7 ⅞" T: 3 ½"
 B: 3 ½" M: 4 ⅝"
 1 Dz.



N2760
 G&T Cocktail (24 Oz.)
 H: 7 ¾" T: 3 ¾"
 B: 3 ¼" M: 4 ½"
 1 Dz.



N6216
 Kyoto (5 Oz.)
 H: 3" T: 3 ⅝"
 B: 2 ¾" M: 3 ⅝"
 16 Pcs.



ES002
 Stemless Cocktail (8 Oz.)
 H: 3 ½" T: 3 ¾"
 B: 2" M: 3 ¾"
 1 Dz.



ES001
 Stemless Cocktail (10 Oz.)
 H: 3 ¾" T: 4 ⅞"
 B: 2 ⅞" M: 4 ⅞"
 1 Dz.

TECHNOLOGY & MATERIAL



★ ★ ★ MARTINIS • COUPES



L0371
 Excalibur Coupe Cocktail (8 Oz.)
 H: 5 5/8" T: 4 3/8"
 B: 3" M: 4 3/8"
 2 Dz.



37652
 Elegance Coupe Cocktail (5 1/4 Oz.)
 H: 4 3/4" T: 3 3/8"
 B: 2 3/4" M: 3 1/2"
 4 Dz.

NEW



P8796
 Broadway Coupe Cocktail
 (8 Oz.)
 H: 5 1/2" T: 4 1/2"
 B: 3" M: 4 1/2"
 1 Dz.



CA030
 Chris Adams Coupe Cocktail (6 Oz.)
 H: 5 3/4" T: 3 1/2"
 B: 2 7/8" M: 3 1/2"
 2 Dz.



CA031
 Chris Adams Coupe Cocktail (6 Oz.)
 H: 5 7/8" T: 3 1/2"
 B: 2 7/8" M: 3 1/2"
 2 Dz.



CA504
 Chris Adams Coupe Cocktail (6 Oz.)
 H: 5 3/4" T: 3 1/2"
 B: 2 7/8" M: 3 1/2"
 2 Dz.

TECHNOLOGY & MATERIAL



— ARCOROC SPARKLING WINE —



Various shapes and sizes from modern to classic to help celebrate every occasion.

SPARKLING WINE ARCOROC

* EFFERVESCENCE PLUS



*

- **H8466**
Malea Brio Flute (3 Oz.)
H: 6 1/16" T: 1 7/8"
B: 2 1/8" M: 2 1/4"
2 Dz.



- **56416**
Elegance Flute (4 1/2 Oz.)
H: 7" T: 1 5/8"
B: 2 1/4" M: 2 1/4"
4 Dz.



- **E6125**
Outdoor Perfect Flute (5 Oz.)
H: 8 1/2" T: 2"
B: 2 3/4" M: 2 1/4"
3 Dz.



- **37652**
Elegance Coupe Cocktail (5 1/4 Oz.)
H: 4 3/4" T: 3 3/8"
B: 2 3/4" M: 3 1/2"
4 Dz.



*

- **H2090**
Mineral Flute (5 1/4 Oz.)
H: 8 3/4" T: 1 3/4"
B: 2 1/2" M: 2 1/8"
2 Dz.



*

- **J1478**
Malea Brio Flute (5 1/4 Oz.)
H: 7 7/8" T: 2 1/8"
B: 2 3/8" M: 2 5/8"
2 Dz.

NEW



- **Q2504**
ArcoPrime Flute (5 3/4 Oz.)
H: 7 7/8" T: 1 15/16"
B: 2 5/8" M: 2 3/16"
1 Dz.



- **71086**
Excalibur Flute (5 3/4 Oz.)
H: 7 3/4" T: 2"
B: 2 1/2" M: 2 1/2"
3 Dz.



- **37298**
Elegance Flute (5 3/4 Oz.)
H: 7" T: 2"
B: 2 1/4" M: 2 1/4"
4 Dz.



- **H0656**
Rutherford Flute (5 3/4 Oz.)
H: 7 7/8" T: 1 15/16"
B: 2 5/8" M: 2 3/8"
2 Dz.

NEW



- **P8793**
Romeo Flute (5 3/4 Oz.)
H: 7 7/8" T: 2"
B: 2 3/8" M: 2 1/8"
1 Dz.

*



- **L8941**
Malea Brio Coupe (7 Oz.)
H: 7 5/8" T: 2 7/8"
B: 3" M: 3 1/4"
2 Dz.

NEW



- **N5082**
V Juliette Flute (7 3/4 Oz.)
H: 8 5/8" T: 1 7/8"
B: 2 7/8" M: 2 5/8"
2 Dz.

*



- **L0371**
Excalibur Coupe Cocktail (8 Oz.)
H: 5 5/8" T: 4 3/8"
B: 3" M: 4 3/8"
2 Dz.

TECHNOLOGY & MATERIAL



ARMORIM
HIGH RIM RESISTANCE



N6374
 Spirit Taster (6 Oz.)
 H: 5" T: 1 3/4"
 B: 2 1/2" M: 3"
 2 Dz.



G3659
 Cabernet Sheer Rocks (7 Oz.)
 H: 2 3/4" T: 2 3/4"
 B: 2 3/8" M: 2 3/4"
 2 Dz.



L5757
 Sequence Rocks (8 1/2 Oz.)
 H: 3 1/4" T: 2 3/4"
 B: 2 1/8" M: 3 1/8"
 1 Dz.



U1032
 Open Up Warm Tumbler (10 Oz.)
 H: 3 3/8" T: 2 3/8"
 B: 1 7/8" M: 3 7/8"
 2 Dz.

★
 ★
 ★
 ★
 ★
 ★
 WHISKEY

TECHNOLOGY & MATERIAL





L5758
 Sequence Rocks (10 ½ Oz.)
 H: 3 ½" T: 3"
 B: 2 ¼" M: 3 ⅜"
 1 Dz.



G3666
 Cabernet Sheer Rocks (10 ½ Oz.)
 H: 3 ¼" T: 3 ⅛"
 B: 2 ⅝" M: 3 ⅝"
 2 Dz.



Q4354
 Rendez-Vous Rocks (10 ¾ Oz.)
 H: 3 ¾" T: 3 ½"
 B: 3" M: 3 ½"
 1 Dz.



Q4353
 Architecte Rocks (10 ¾ Oz.)
 H: 3 ⅞" T: 3 ½"
 B: 2 ¾" M: 3 ½"
 1 Dz.



Q4337
 Macassar Rocks (10 ¾ Oz.)
 H: 3 ⅞" T: 3 ¾"
 B: 2 ⅞" M: 3 ¾"
 1 Dz.



G3367
 Lima Old Fashioned (11 ¾ Oz.)
 H: 3 ¼" T: 2 ⅞"
 B: 2 ⅛" M: 3 ½"
 2 Dz.



L2370
 Cabernet Sheer Double Old Fashioned (12 ½ Oz.)
 H: 3 ½" T: 3 ⅜"
 B: 2 ⅞" M: 3 ½"
 2 Dz.



L8507
 Aska Tumbler (12 ¾ Oz.)
 H: 4" T: 2 ¾"
 B: 3 ½" M: 3 ½"
 2 Dz.



L5756
 Sequence Double Old Fashioned (13 ½ Oz.)
 H: 3 ⅝" T: 3"
 B: 2 ⅝" M: 3 ⅝"
 1 Dz.



U1033
 Open Up Old Fashioned (13 ½ Oz.)
 H: 3 ¾" T: 2 ¾"
 B: 1 ⅞" M: 3 ⅝"
 2 Dz.

TECHNOLOGY & MATERIAL



★
 ★
 ★
 ★
 ★
 W H I S K E Y



J4238
Islande Whiskey (3 ¼ Oz.)
H: 3 7/16" T: 2"
B: 1 7/8" M: 2"
2 Dz.



N0529 ●●
Urbane Whiskey/Shot (3 ½ Oz.)
H: 3" T: 2 5/8"
B: 1 5/8" M: 2 5/8"
1 Dz.

NEW



L6119
Kenzie Taster (5 ¾ Oz.)
H: 4" T: 2"
B: 2 1/8" M: 2 5/8"
3 Dz.



J4241
Islande Old Fashioned (7 Oz.)
H: 3 1/4" T: 2 3/4"
B: 2 5/8" M: 2 3/4"
2 Dz.



P8496 ●
Precision Rocks (7 ½ Oz.)
H: 3 3/8" T: 2 7/8"
B: 2 5/8" M: 2 7/8"
1 Dz.



12652
Islande Old Fashioned (8 ½ Oz.)
H: 3 3/8" T: 3 1/8"
B: 3" M: 3 1/8"
4 Dz.

★
★
★
W H I S K E Y

TECHNOLOGY & MATERIAL

ARMORIM
HIGH RIM RESISTANCE





N0531 ●●
 Urbane Rocks (9 Oz.)
 H: 3 7/8" T: 3 1/2"
 B: 2 1/4" M: 3 1/2"
 1 Dz.



J4239
 Islande Old Fashioned (10 Oz.)
 H: 3 5/8" T: 3 1/8"
 B: 3" M: 3 1/8"
 2 Dz.



P8500 ●
 Precision Rocks (10 1/2 Oz.)
 H: 3 1/4" T: 3 1/4"
 B: 3" M: 3 1/4"
 1 Dz.



L7254
 Broadway Rocks (10 1/2 Oz.)
 H: 3 1/2" T: 3 3/8"
 B: 3" M: 3 3/8"
 2 Dz.



P4188
 Brixton Rocks (10 1/2 Oz.)
 H: 3 3/4" T: 3 3/8"
 B: 2 13/16" M: 3 3/8"
 1 Dz.



N5995 ●
 V Juliette Double Old Fashioned (11 3/4 Oz.)
 H: 3 1/4" T: 3"
 B: 2 1/4" M: 3 3/4"
 2 Dz.



N0524 ●●
 Urbane Double Old Fashioned (12 Oz.)
 H: 4 1/8" T: 3 3/4"
 B: 2 3/8" M: 3 3/4"
 1 Dz.



N6377
 Islande Double Old Fashioned (12 3/4 Oz.)
 H: 3 3/4" T: 3 1/2"
 B: 3 3/16" M: 3 1/2"
 2 Dz.



P8495 ●
 Precision Double Old Fashioned (14 Oz.)
 H: 4" T: 3 1/4"
 B: 3" M: 3 1/4"
 1 Dz.

TECHNOLOGY & MATERIAL



ARCOROC SHOTS



Made for your highly vigorous venue but designed for your style and aesthetics.



21554
Hot Shot (1 ¼ Oz.)
H: 2 ¾" T: 1 ¾"
B: 1 ⅝" M: 1 ¾"
2 Dz.



L7253
Shot (2 Oz.)
H: 2 ¾" T: 1 ⅞"
B: 1 ½" M: 1 ⅞"
2 Dz.



G2639
Hot Shot (2 ½ Oz.)
H: 3 ⅝" T: 2 ⅞"
B: 1 ½" M: 2 ⅞"
4 Dz.



19188
Square Shot Glass (2 ½ Oz.)
H: 2 ⅞" T: 2 ⅝"
B: 2" M: 2 ⅝"
6 (1 Dz. Packs)



H5057
Shot Glass (1 ¾ Oz.)
H: 2 ¼" T: 1 ⅝"
B: 1 ⅞" M: 1 ⅝"
6 Dz.



N5834
Salto Cordial (2 Oz.)
H: 2 ½" T: 1 ⅞"
B: 1 ⅞" M: 1 ⅞"
4 Dz.



00016
Shot Glass (1 ¼ Oz.)
H: 2" T: 1 ⅝"
B: 1" M: 1 ⅝"
2 Dz.



C3966
Tall Square Shot Glass (2 ¾ Oz.)
H: 3 ¾" T: 1 ⅞"
B: 1 ⅝" M: 1 ⅞"
6 Dz.



40375
Islande Cordial (2 ¼ Oz.)
H: 4 ⅞" T: 1 ½"
B: 1 ⅞" M: 1 ½"
6 Dz.



47346
Cabernet Cordial (2 ½ Oz.)
H: 3 ½" T: 1 ½"
B: 1 ⅞" M: 1 ⅝"
4 Dz.

TECHNOLOGY & MATERIAL





E5358
 Cabernet Cordial (2 ¼ Oz.)
 H: 5 ¼" T: 1 ⅝"
 B: 2" M: 1 ⅞"
 2 Dz.



14798
 Cabernet Port (4 Oz.)
 H: 5 ⅞" T: 1 ⅝"
 B: 2" M: 2 ⅛"
 2 Dz.



NEW

N8212
 Cordial (4 Oz.)
 H: 7 ⅞" T: 1 ½"
 B: 2 ⅜" M: 2"
 2 Dz.

NEW



N6374
 Spirit Taster (6 Oz.)
 H: 5" T: 1 ¾"
 B: 2 ½" M: 3"
 2 Dz.

NEW



N8172
 Brandy (24 Oz.)
 H: 6 ¾" T: 2 ⅞"
 B: 3 ¼" M: 4 ⅞"
 2 Dz.



U1032
 Open Up Warm Tumbler (10 Oz.)
 H: 3 ⅜" T: 2 ⅜"
 B: 1 ⅞" M: 3 ⅞"
 2 Dz.

TECHNOLOGY & MATERIAL



★
 ★
 ★
 ★
 ★
 AFTER DINNER



• **71079**
 Excalibur Brandy (12 Oz.)
 H: 5 1/4" T: 2"
 B: 2 1/8" M: 2 3/8"
 2 Dz.



62664
 Cabernet Brandy (13 3/4 Oz.)
 H: 5 1/6" T: 2 1/2"
 B: 3 1/4" M: 3 3/4"
 24 Pcs.



G1420
 Grappa (3 Oz.)
 H: 6 1/4" T: 1 1/16"
 B: 2 3/16" M: 2 3/16"
 2 Dz.



42258
 Viticole (4 1/4 Oz.)
 H: 5 1/8" T: 1 9/16"
 B: 2" M: 2 1/8"
 2 Dz.



L6119
 Kenzie Taster (5 3/4 Oz.)
 H: 4" T: 2"
 B: 2 1/8" M: 2 5/8"
 3 Dz.

TECHNOLOGY & MATERIAL





Elegant selections for the increasing demand for craft beers.



N8281
 Reveal Up (13 ½ Oz.)
 H: 8" T: 2 ¼"
 B: 3 ¼" M: 3 ¾"
 2 Dz.



N8279
 Sublym (15 Oz.)
 H: 8 ¾" T: 2 ¾"
 B: 3" M: 3 ½"
 2 Dz.



E2790
 Young Wine (16 Oz.)
 H: 8 ½" T: 2 ⅝"
 B: 3 ¼" M: 3 ⅜"
 2 Dz.



U1013
 Tannic (18 ½ Oz.)
 H: 9 ⅛" T: 2 ¾"
 B: 3 ¼" M: 4 ⅛"
 2 Dz.

★
 ★
 ★
 ★
 ★
 ★
 B E E R

T E C H N O L O G Y & M A T E R I A L



ARCOROC FOOTED BEER



ARCOROC MIXING/PUB GLASSES



● **43716**
Nonic Tumbler (10 Oz.)
H: 4 1/2" T: 2 1/16"
B: 2 1/16" M: 2 7/8"
4 Dz.



●● **H3856**
Beverage (14 Oz.)
H: 5 1/16" T: 3 1/4"
B: 2 1/4" M: 3 1/4"
1 Dz.



● **N3950**
Mixing Glass, Heavy Sham (14 Oz.)
H: 5 3/4" T: 3 1/2"
B: 2 3/8" M: 3 1/2"
2 Dz.



● **J4089**
Mixing Glass (14 Oz.)
H: 5 3/4" T: 3 1/2"
B: 2 3/8" M: 3 1/2"
2 Dz.



43100
Mixing Glass, Heavy Sham (14 Oz.)
H: 5 3/4" T: 3 1/2"
B: 2 3/8" M: 3 1/2"
2 Dz.



● **19343**
Mixing Glass (16 Oz.)
H: 5 3/4" T: 3 1/2"
B: 2 3/8" M: 3 1/2"
2 Dz.



●● **H3089**
Cooler (16 Oz.)
H: 5 3/4" T: 3 7/16"
B: 2 3/8" M: 3 7/16"
1 Dz.



●●● **E8792**
Nonic Tumbler (16 Oz.)
H: 5 5/8" T: 3 1/8"
B: 2 1/2" M: 3 3/16"
4 Dz.



●● **J0825**
Tulip Tumbler (16 Oz.)
H: 5 3/4" T: 3 1/16"
B: 2 1/2" M: 3 5/16"
2 Dz.



●●● **52643**
Tulip Tumbler (16 Oz.)
H: 5 3/4" T: 3 1/16"
B: 2 1/2" M: 3 5/16"
2 Dz.



● **J4106**
Mixing Glass (16 Oz.)
H: 5 3/4" T: 3 1/2"
B: 2 3/8" M: 3 1/2"
2 Dz.



G3960
Mixing Glass (16 Oz.)
H: 5 3/4" T: 3 1/2"
B: 2 3/8" M: 3 1/2"
2 Dz.



E5458
Can Cooler (16 Oz.)
H: 5 1/4" T: 2 5/8"
B: 2 1/2" M: 3"
3 Dz.



L4865
Tall Can Cooler (16 Oz.)
H: 6 1/2" T: 2 1/4"
B: 2 1/2" M: 2 5/8"
2 Dz.

★ ★ ★ BEER

TECHNOLOGY & MATERIAL



ARMORIM
HIGH RIM RESISTANCE



MIXING/PUB GLASSES **ARCOROC**



24668
Willi Tumbler (13 1/2 Oz.)
H: 5 7/8" T: 2 5/8"
B: 2" M: 2 5/8"
1 Dz.



C5872
Willi Tumbler (16 Oz.)
H: 6 3/8" T: 2 15/16"
B: 2 1/4" M: 3 1/16"
1 Dz.



L5711
Barlow (16 Oz.)
H: 5 3/8" T: 3"
B: 2 1/2" M: 3 1/2"
2 Dz.



J8821
Party Mixing Glass (16 Oz.)
H: 4 7/8" T: 3 3/4"
B: 2 1/2" M: 3 3/4"
2 Dz.



● **49357**
Nonic Tumbler (20 Oz.)
H: 5 15/16" T: 3 3/8"
B: 2 5/8" M: 3 7/16"
4 Dz.



● **P3008**
Tulip Tumbler (20 Oz.)
H: 6 3/8" T: 3 1/16"
B: 2 5/8" M: 3 5/16"
2 Dz.



● **22032**
Mixing Glass (20 1/2 Oz.)
H: 6 3/4" T: 3 5/8"
B: 2 3/8" M: 3 5/8"
2 Dz.



● **L8970**
Mixing Glass (22 Oz.)
H: 7" T: 3 5/8"
B: 2 1/2" M: 3 5/8"
2 Dz.

TECHNOLOGY & MATERIAL



BEER ★★

— ARCOROC PILSNER —





25263
Linz (13 1/2 Oz.)
H: 8 1/8" T: 2 3/4"
B: 2 1/16" M: 2 3/4"
2 Dz.



N2644
Classic Pilsner (14 Oz.)
H: 9" T: 3 1/8"
B: 3 1/4" M: 3 1/4"
1 Dz.



D0129
Specialty Pilsner (15 Oz.)
H: 8 3/8" T: 2 5/8"
B: 2 7/8" M: 2 7/8"
2 Dz.



04900
Martigues (16 Oz.)
H: 8 5/8" T: 3 1/4"
B: 2 1/2" M: 3 1/4"
2 Dz.



21053
Grand Pilsner (16 Oz.)
H: 8 3/8" T: 2 7/8"
B: 2 1/2" M: 2 7/8"
3 Dz.



H9211
Linz (18 1/2 Oz.)
H: 7 1/2" T: 3 1/8"
B: 3 1/4" M: 3 1/4"
2 Dz.



19416
Grand Pilsner (20 Oz.)
H: 8 7/16" T: 3 1/4"
B: 2 3/4" M: 3 1/4"
2 Dz.



19415
Grand Pilsner (23 Oz.)
H: 9" T: 3 1/4"
B: 2 3/4" M: 3 1/4"
2 Dz.



36229
Pub Pilsner (23 Oz.)
H: 9" T: 3 1/8"
B: 2 7/8" M: 3 3/8"
2 Dz.



E6141
Outdoor Perfect Pilsner (23 Oz.)
H: 10" T: 3 1/4"
B: 2 7/8" M: 3 1/4"
3 Dz.



25275
Linz (23 Oz.)
H: 8 1/2" T: 3 5/16"
B: 3 1/4" M: 3 5/16"
2 Dz.

TECHNOLOGY & MATERIAL



ARCOROC SAMPLERS



SAMPLERS ARCOROC



D2443
Bell Taster (7 ¼ Oz.)
H: 4" T: 2 ½"
B: 1 7/8" M: 2 5/8"
6 Dz.



L6119
Kenzie Taster (5 ¾ Oz.)
H: 4" T: 2"
B: 2 1/8" M: 2 5/8"
3 Dz.



***FG688** Beer Paddle 16" x 3 ¼" 1 Dz.
Hole Dimension: 2"
*Hand Wash ONLY



***FK856** Hollow Beer Paddle 16" x 3 ¼" 1 Dz.
Hole Dimension: 2"
*Hand Wash ONLY

Glassware Recommendations:
D2443, L6119, N0529, J4238, J4094

Glassware Recommendations:
D2443, L6119, N0529, J4238, J4094

MUGS ARCOROC



C0790
Dayton Mug (22 Oz.)
H: 8 5/8" T: 3"
B: 3 3/8" M: 3 3/8"
1 Dz.



53404
Sport Mug (25 Oz.)
H: 6 5/8" T: 3 5/8"
B: 4" M: 6"
1 Dz.



C1643
Mug (10 Oz.)
H: 5 7/8" T: 2 7/8"
B: 3 1/4" M: 4 7/8"
1 Dz.

★
★
★
B E R



Designed to aerate wine or beautifully display spirits.

DECANTERS & CARAFES



D6653
Open Up Decanter (47 ¼ Oz.)
H: 12 5/16"
M: 5 3/4"
2 Pcs.



D2138
Explore Decanter (43 ¾ Oz.)
H: 12 5/8"
M: 5 5/8"
2 Pcs.



D2142
Opening Decanter (30 ¼ Oz.)
H: 9 3/8"
M: 8 3/8"
2 Pcs.



62451
Millesime Carafe, Magnum (67 ½ Oz. - 2 L)
H: 9 ½" T: 2 3/8"
B: 4 ¼" M: 8 ¼"
2 Pcs.

TECHNOLOGY & MATERIAL



NEW



FL470
Carafe
(10 Oz. - 6 Oz. to neck)
H: 4 3/4" T: 2 3/8"
B: 3" M: 3"
2 Dz.
Approximate Pour Line



D1C08365
Wave Carafe (with blue wave pour line)
(8 1/4 Oz. - 5 Oz. to pour line)
H: 5 1/4" T: 2 1/4"
B: 2 1/4" M: 3 1/8"
1 Dz.
Approximate Pour Line



FE644
By the Glass Carafe
(6 Oz.* to the neck bottom)
H: 6" T: 2"
B: 1 7/8" M: 2 3/4"
2 Dz.
* Due to the nature of the mouthblown design capacities may vary up to 0.5 Oz.



C0198
Carafe (8 1/4 Oz. - 1/4 L)
H: 5 1/4" T: 2 1/4"
B: 2 1/4" M: 3 1/8"
1 Dz.



33040
Carafe (17 Oz. - 1/2 L)
H: 6 1/2" T: 2 3/16"
B: 2 3/4" M: 3 7/8"
1 Dz.



10291
Carafe (33 3/4 Oz. - 1L)
H: 8" T: 3"
B: 3 7/8" M: 4 5/8"
6 Pcs.



53673
Carafe (17 Oz. - 1/2 L)
H: 7 3/4" T: 1 5/8"
B: 3 1/8" M: 3 1/8"
1 Dz.



53675
Carafe (33 3/4 Oz. - 1L)
H: 10" T: 2 1/8"
B: 3 3/4" M: 3 3/4"
6 Pcs.



FJ004
Bystro Grand Carafe
(8 1/2 Oz. - 1/4 L)
H: 8 1/2" T: 2 1/8"
B: 2 1/4" M: 2 1/4"
6 Pcs.



FJ003
Bystro Grand Carafe
(17 Oz. - 1/2 L)
H: 10 3/8" T: 2 5/8"
B: 2 5/8" M: 2 3/4"
6 Pcs.



FJ002
Bystro Grand Carafe
(33 3/4 Oz. - 1L)
H: 12 1/4" T: 3 1/4"
B: 3 1/2" M: 3 3/8"
6 Pcs.



FL200
Clear Carafe (22 Oz.)
H: 7 1/2" W: 2 7/8"
M: 3 1/4"
1 Dz.



FL203
Clear Carafe (30 Oz.)
H: 6" W: 4"
M: 4 3/8"
16 Pcs.

★ ★ ★ ★
 DECANTERS,
 CARAFES &
 PITCHERS



L4213
 Fluid Carafe (4 Oz.)
 H: 4 3/8" M: 2 1/4"
 1 Dz.



L4212
 Fluid Carafe (8 1/4 Oz.)
 H: 5 1/4" M: 2 3/4"
 1 Dz.



L3963
 Fluid Carafe (16 3/4 Oz.)
 H: 7 1/2" M: 3 1/2"
 6 Pcs.



L4194
 Fluid Carafe with stopper (16 3/4 Oz.)
 H: 7 1/2" M: 3 1/2"
 6 Pcs.





25 1/4 Oz.

L6247
Fluid Carafe (25 1/4 Oz.)
H: 8 1/4" M: 3 3/8"
6 Pcs.



25 1/4 Oz.

L8689
Fluid Carafe with stopper (25 1/4 Oz.)
H: 8 1/4" M: 3 3/8"
6 Pcs.

NEW



25 1/4 Oz.

Q4033
Fluid Carafe Frost Blue (25 1/4 Oz.)
H: 8 1/4" M: 3 3/8"
6 Pcs.

NEW



25 1/4 Oz.

Q4025
Fluid Carafe Frost Green (25 1/4 Oz.)
H: 8 1/4" M: 3 3/8"
6 Pcs.

NEW



25 1/4 Oz.

Q4026
Fluid Carafe Frost (25 1/4 Oz.)
H: 8 1/4" M: 3 3/8"
6 Pcs.



33 3/4 Oz.

L3965
Fluid Carafe (33 3/4 Oz.)
H: 10 3/8" M: 4 1/8"
6 Pcs.



33 3/4 Oz.

L4193
Fluid Carafe with stopper (33 3/4 Oz.)
H: 10 3/8" M: 4 1/8"
6 Pcs.

NEW



L4257
Black Stopper (fits L6247, Q4033, Q4025, Q4026 and L4194)
H: 1 1/2" M: 2 3/4"
2 Dz.

ARCOROC PITCHERS

★ ★ ★ ★ ★
 DECANTERS, CARAFES & PITCHERS



FJ001
 Bystro Pitcher (10 ¼ Oz. - .3L)
 H: 5 ½" T: 2 ⅞"
 B: 1 ⅞" M: 3 ¼"
 6 Pcs.



FH998
 Bystro Pitcher (33 ¾ Oz. - 1L)
 H: 7 ½" T: 4"
 B: 2 ⅞" M: 4 ½"
 6 Pcs.



55239
 Pitcher with Pour Lip (44 Oz.)
 H: 7 ¾" T: 4 ¼"
 B: 3 ¼" M: 7"
 6 Pcs.



E7258
 Pitcher with Pour Lip (16 Oz.)
 H: 5 ¾" T: 3 ⅞"
 B: 3 ⅜" M: 5"
 12 Pcs.



E7255
 Pitcher with Pour Lip (34 Oz.)
 H: 8" T: 3 ⅞"
 B: 3 ⅜" M: 5 ¾"
 6 Pcs.



E7254
 Pitcher with Pour Lip (44 Oz.)
 H: 8 ½" T: 4"
 B: 4" M: 8 ⅜"
 6 Pcs.



C0678
 Pitcher with Pour Lip (60 Oz.)
 H: 9" T: 5 ¾"
 B: 4 ½" M: 8 ¼"
 6 Pcs.



E6124
 Outdoor Perfect Pitcher with Pour Lip (67 ½ Oz.)
 H: 10 ¼" T: 9"
 B: 3 ¼" M: 9"
 1 Dz.

TECHNOLOGY & MATERIAL





J3811
Votive (3 Oz.)
H: 2 1/2" T: 1 15/16"
B: 2" M: 2"
3 Dz.



FK596
Mixing Beaker (20 Oz.)
H: 6 1/4" T: 3 1/2"
B: 3 1/2" M: 3 1/2"
8 Pcs.



FH517
Yarai Mixing Glass (14 3/4 Oz.)
H: 5 3/4" T: 4 3/8"
B: 3 1/2" M: 3 1/2"
4 Pcs.

ASHTRAYS **ARCOROC**



C1320
Clear
H: 1 3/8" T: 4 1/4"
B: 3 1/2" M: 4 1/4"
2 Dz.



51257
Clear
H: 1 1/4" T: 3 1/4"
B: 2 7/8" M: 3 1/4"
2 Dz.



00187
Black
H: 1 3/8" T: 4 1/4"
B: 3 1/2" M: 4 1/4"
2 Dz.



55878
Black
H: 1 1/4" T: 3 1/4"
B: 2 7/8" M: 3 1/4"
2 Dz.

TECHNOLOGY & MATERIAL





CAP07
Ellis Bar Knife
L: 8 15/16"
1 Pc.



CA008
Ellis Sharpening Stone
L: 6 3/8"
1 Pc.



CAP12
Bar Knife/Sharpener Case *Fits CAP07 and CA008
Bar Knife and Sharpening Stone NOT included
1 Pc.



FK596
Mixing Beaker (20 Oz.)
H: 6 1/4" T: 3 1/2"
B: 3 1/2" M: 3 1/2"
8 Pcs.



FH517
Yarai Mixing Glass (14 3/4 Oz.)
H: 5 3/4" T: 4 3/8"
B: 3 1/2" M: 3 1/2"
4 Pcs.

NEW



OL167
Bitters Bottle/ Dasher Top (5 Oz.)
H: 4 3/8" T: 1 9/16"
B: 2 3/8" M: 2 3/8"
1 Pc.

NEW Silicone 1/2" Bands (6 Pcs.)
(Colors Sold Separately)

- RBP04** Purple
- RBB02** Blue
- RBP01** Pink
- RBY03** Yellow
- RBDG3** Green
- RBO05** Orange
- RBW06** White
- RBR09** Red
- RBB06** Black
- RBBR7** Brown



NEW



OL166
Juice Bottle (16 Oz.)
H: 10 1/8" T: 1 1/8"
B: 2 3/8" M: 2 3/8"
6 Pcs.

MIX **ARCOROC**
BY
Chris Adams



MT849
Black Matte Shaker Tin (28 Oz.)
H: 7" T: 3 5/8"
B: 2 3/8" M: 3 5/8"
1 Pc.



CAP28
Shaker Tin (28 Oz.)
H: 7" T: 3 5/8"
B: 2 3/8" M: 3 5/8"
1 Pc.



The Mix Collection, designed by world renowned mixologist, Chris Adams, was made to withstand the rigor of high volume restaurants and bars, while still focusing on the craft.



MT850
Black Matte Shaker Tin (20 Oz.)
H: 5 1/2" T: 3 1/2"
B: 2 3/8" M: 3 1/2"
1 Pc.



CAP20
Shaker Tin (20 Oz.)
H: 5 1/2" T: 3 1/2"
B: 2 3/8" M: 3 1/2"
1 Pc.



CAP18
Shaker Tin (18 Oz.)
H: 5 1/4" T: 3 7/16"
B: 2 3/8" M: 3 7/16"
1 Pc.



CAP09
Muddler
L: 9 1/2"
1 Pc.

Above shakers fit perfectly within each other or with any pint mixing glass.

See Through Silicone Gauge!



MT051
Ellis Jigger Black Matte
H: 3 1/4" T: 2"
B: 1 3/4" M: 2"
1 Pc.



CAP14
Ellis Adams Jigger Matte
H: 3 1/4" T: 2"
B: 1 3/4" M: 2"
1 Pc.



CAP32
Stainless Jigger
H: 3 1/4" T: 2"
B: 1 3/4" M: 2"
1 Pc.
*Inner Oz. indicators

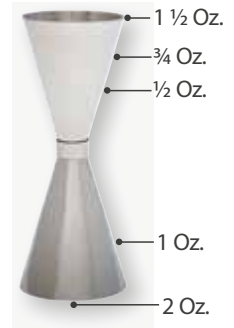

CAP51
Tall Stainless Jigger
H: 5 1/8" T: 2"
B: 1 7/8" M: 2"
1 Pc.
*Inner Oz. indicators



CAP08
Dual Sided Hammer
Bar Spoon
L: 15 1/2"
1 Pc.



CAP05
Dual Sided Paddle
Bar Spoon
L: 15 3/4"
1 Pc.



CAP11
Dual Sided Teardrop
Bar Spoon
L: 15 3/4"
1 Pc.



MT011
Dual Sided Teardrop Bar
Spoon Black Matte
L: 15 3/4"
1 Pc.



CAP04
Fine Mesh Strainer
L: 8 3/4" W: 3 1/8"
1 Pc.



MT004
Fine Mesh Strainer
Black Matte
L: 8 3/4" W: 3 1/8"
1 Pc.



CAP06
Ice Tongs
L: 6 1/2"
1 Pc.



CAP01
Tweezers
L: 6 1/4"
1 Pc.

MIX

ARCOROC
BY
Chris Adams



NEW



HS001
Hawthorne Strainer Stainless
L: 6 1/4" W: 3 3/8"
1 Pc.

NEW



HS002
Hawthorne Strainer Black Matte
L: 6 1/4" W: 3 3/8"
1 Pc.



CAP02
Julep Strainer
L: 7 1/16" W: 3"
1 Pc.



MT002
Julep Strainer Black Matte
L: 7 1/16" W: 3"
1 Pc.

★
★
★
BARWARE

ARCOROC OUTDOOR PERFECT



Made from fully recyclable, BPA-Free S.A.N. plastic. Tests have shown no deterioration in the material up to 2,000 cycles in an industrial dishwasher. In addition, pieces feature water vents on the bottom to allow proper drainage.

For Cold Beverages ONLY



E6134
Rocks (10 Oz.)
H: 4 1/2" T: 3 1/4"
B: 2" M: 3 1/4"
3 Dz.



E6137
Double Old Fashioned (14 3/4 Oz.)
H: 4 1/2" T: 3 3/4"
B: 2 5/8" M: 3 3/4"
3 Dz.



E6139
Cooler (19 3/4 Oz.)
H: 6 3/8" T: 3 3/4"
B: 2 3/8" M: 3 3/4"
3 Dz.



E6136
Hi Ball (12 3/4 Oz.)
H: 6 1/4" T: 3"
B: 1 7/8" M: 3 1/4"
3 Dz.

E6138
Hi Ball (16 Oz.)
H: 7" T: 3 1/8"
B: 2 1/8" M: 3 1/8"
3 Dz.



E6131
Wine (10 Oz.)
H: 7 3/8" T: 2 7/8"
B: 3" M: 3"
3 Dz.



FM120
Stemless Wine (15 Oz.)
H: 4 3/8" T: 2 1/2"
B: 1 7/8" M: 3 3/8"
3 Dz.



E6125
Flute (5 1/2 Oz.)
H: 8 1/2" T: 2"
B: 2 3/4" M: 2 1/4"
3 Dz.



E6140
Mug (21 3/4 Oz.)
H: 5 5/8" T: 3 3/8"
B: 3 1/4" M: 4 3/4"
3 Dz.



E6141
Pilsner (23 Oz.)
H: 10" T: 3 1/4"
B: 2 7/8" M: 3 1/4"
3 Dz.



E6124
Pitcher (67 1/2 Oz.)
H: 10 1/4" T: 9"
B: 3 1/4" M: 9"
1 Dz.



E6128
Hurricane (14 3/4 Oz.)
H: 9 1/8" T: 2 7/8"
B: 3" M: 2 7/8"
3 Dz.



E6132
Cocktail (10 Oz.)
H: 7 3/8" T: 4 3/4"
B: 3 1/4" M: 4 5/8"
2 Dz.



E6127
Margarita (12 Oz.)
H: 6 7/8" T: 4 7/8"
B: 3 1/4" M: 4 3/4"
2 Dz.



E6133
Shot Glass (3 Oz.)
H: 3 5/8" T: 2 1/8"
B: 1 1/8" M: 2"
3 Dz.

TECHNOLOGY & MATERIAL



For Cold Beverages ONLY



Made from fully recyclable, BPA-Free S.A.N. plastic, the blue extension of Outdoor Perfect allows you to mix and match for a perfect outdoor experience. Pieces feature water vents on the bottom to allow for proper drainage.

★
★
★
S.A.N. PLASTIC



FM400
Blue Rocks (10 Oz.)
H: 4 1/2" T: 3 1/4"
B: 2" M: 3 1/4"
3 Dz.



ODP36
Blue Hi Ball (12 3/4 Oz.)
H: 6 1/4" T: 3"
B: 1 7/8" M: 3 1/4"
3 Dz.



FM402
Blue Hi Ball (16 Oz.)
H: 7" T: 3 1/8"
B: 2 1/8" M: 3 1/8"
3 Dz.



FM403
Blue Cooler (19 3/4 Oz.)
H: 6 3/8" T: 3 3/4"
B: 2 3/8" M: 3 3/4"
3 Dz.

TECHNOLOGY & MATERIAL



For Cold Beverages ONLY

NEW

OUTDOOR PERFECT STACKABLE

S.A.N. PLASTIC

ARCOROC



Made from fully recyclable, BPA-Free S.A.N. plastic, this new design offers all the great features of Outdoor Perfect, elevated with a stackable profile for easy space saving and a clean design for multi use.



S.A.N. PLASTIC



FN090
Rocks (10 1/2 Oz.)
H: 3 5/8" T: 3 5/8"
B: 2 1/2" M: 3 3/8"
3 Dz.



FN091
Double Old Fashioned (12 Oz.)
H: 3 7/8" T: 3 5/8"
B: 2 1/16" M: 3 3/16"
3 Dz.



FN092
Beverage (14 Oz.)
H: 5 1/16" T: 3 1/4"
B: 2 1/4" M: 3 1/4"
3 Dz.



FN093
Cooler (16 Oz.)
H: 5 3/4" T: 3 7/16"
B: 2 3/8" M: 3 7/16"
3 Dz.

TECHNOLOGY & MATERIAL



For Cold Beverages ONLY

DINNERWARE

Set a Place for Extraordinary

When it comes to dinnerware, you want style, strength, selection and value. Your customers want something special. We offer designs from casual to elegant to extraordinary – in materials that have revolutionized the tableware industry.



In total harmony with the Chef&Sommelier glassware, the dinnerware collections are also designed to enhance presentations. Specifically, offering a beautiful canvas to chefs' creations.

Offering a variety of materials and designs, collections are made made in Bone China, Stoneware or in Vitrified Ceramic celebrating the refinement, finesse and resistance within the Chef & Sommelier brand.



Over 200 Years of Heritage: Renowned craft potters, the prestigious Dudson brand carries a rich heritage dating back to 1800. With inspirational products recognized by chefs worldwide for their industrial toughness and authentic design.



Resistant to the pressure and intense pace of professional use, Arcoroc's dinnerware collections have many technical advantages that allow for optimal service.

Arcoroc makes resistance its priority. Collections offered in Extra Strong Porcelain are up to 2x more resistant than standard porcelain. Also, collections made in Opal, a tempered glass that is 3x more resistant than ceramic, is an ideal solution for a long lasting service.

Arcoroc dinnerware goes beyond the table with durable materials and innovative design solutions for sustainable take-away, oven ware and hot drinks, to cover all the needs of your establishment.

Crafted Excellence

Dudson Hand Crafted Collections – Made in England and designed with industrial toughness. Every piece is individually glazed by hand leaving an original 'makers mark' on the reverse, highlighting the hand crafted nature.



Durability – All Dudson ceramics have a fully vitrified body which creates a "closed" structure. The result of this is a very strong and durable product.



Bone China – Brilliant translucence developed with bone ash for maximum strength in ceramic.



Stoneware – Vitrified stoneware ceramic made from clay and fired at high temperature(s) combining artisanal design with industrial strength.



Fully Glazed Foot – Pin firing. Fully glazed foot prevents scratching and cross contamination when product is stacked



Stackability – Product design specifically made for safe stacking.



Extra Strong Porcelain – Developed for professional use; superior mechanical resistance.



Safeguard the Arc Way Developed by Arc

Opal® – Preferred by high volume establishments for strength, stackability, bacteria resistance, style and value.



Fully Tempered – Preferred by high volume establishments for strength, style and value.



DUDSON

The Maker's Collection: URBAN NEW



The Maker's Collection Urban, a burnished effect inspired by the industrial history of UK made ceramics. Urban mimics the worn, man-made textures of industrial landscapes. Decorated under a semi-matte glaze for toughness, Urban is designed for professional use. Available in Steel Grey and Lamp Black, the Urban color palette reflects the raw luxury of contemporary interior design.

NEW

The Maker's Collection: URBAN

VITRIFIED CERAMIC



★ **Narrow Rim Plate** FN555 FN462 Lamp Black Steel Grey 6" 1 Dz.

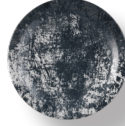

★ **Narrow Rim Plate** FN553 FN461 Lamp Black Steel Grey 7" 1 Dz.



★ **Narrow Rim Plate** FN552 FN460 Lamp Black Steel Grey 8" 1 Dz.

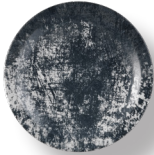

★ **Narrow Rim Plate** FN551 FN459 Lamp Black Steel Grey 9" 1 Dz.

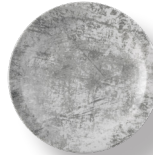

★ **Narrow Rim Plate** FN550 FN458 Lamp Black Steel Grey 10" 1 Dz.

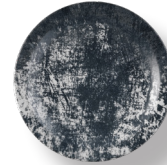

★ **Narrow Rim Plate** FN549 FN457 Lamp Black Steel Grey 11" 1 Dz.



★ **Deep Coupe Plate** FN560 FN466 Lamp Black Steel Grey 10" 1 Dz.



★ **Deep Coupe Plate** FN559 FN465 Lamp Black Steel Grey 11" 1 Dz.



★ **Coupe Bowl** FN557 FN464 Lamp Black Steel Grey 7 1/4" 15 oz. 1 Dz.

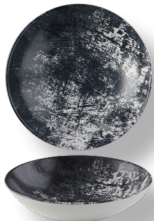

★ **Coupe Bowl** FN556 FN463 Lamp Black Steel Grey 9 3/4" 40 oz. 1 Dz.



Organic Rectangular Plate FN561 FN467 Lamp Black Steel Grey 10 5/8" x 6 1/4" 1 Dz.



Organic Rectangular Plate FN562 FN468 Lamp Black Steel Grey 13 5/8" x 6 1/4" 6 pc.

★ ★ ★ ★ ★
D I N N E R W A R E

T E C H N O L O G Y & M A T E R I A L





Finca is a multi-tonal print that mimics the worn textures of rustic interiors and architectural designs. Crafted and creative, Finca is finished in a semi-matte, hand dipped glaze, enhancing the character of the collection and leaving original 'makers marks' on the reverse of each piece. Decorated in-glaze for industrial toughness, The Maker's Collection is designed for professional use.

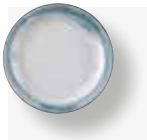

★ **Narrow Rim Plate**
6"
1 Dz.

FN526 Sandstone
FN502 Limestone



★ **Narrow Rim Plate**
8"
1 Dz.

FN525 Sandstone
FN501 Limestone



★ **Narrow Rim Plate**
9"
1 Dz.

FN524 Sandstone
FN500 Limestone

TECHNOLOGY & MATERIAL



NEW

The Maker's Collection: FINCA

VITRIFIED CERAMIC



★ **Narrow Rim Plate** FN523 Sandstone
FN499 Limestone
10"
1 Dz.



★ **Narrow Rim Plate** FN522 Sandstone
FN498 Limestone
11"
1 Dz.



★ **Narrow Rim Bowl** FN527 Sandstone
FN503 Limestone
8 1/4"
1 Dz.



★ **Organic Coupe Plate** FN517 Sandstone
FN493 Limestone
10 3/4"
1 Dz.



★ **Organic Coupe Plate** FN518 Sandstone
FN494 Limestone
9"
1 Dz.



★ **Organic Coupe Bowl** FN519 Sandstone
FN495 Limestone
9 3/4" 28 oz.
1 Dz.



Organic Rectangular Plate FN520 Sandstone
FN496 Limestone
10 5/8" x 6 1/4"
1 Dz.



Organic Rectangular Plate FN521 Sandstone
FN497 Limestone
13 5/8" x 6 1/4"
6 pcs.



★ **Cappuccino Cup** FN528 Sandstone
FN504 Limestone
12 oz.
H: 6.5 cm
1 Dz.



★ **Coffee/Tea Cup** FN529 Sandstone
FN505 Limestone
8 oz.
H: 5.5 cm
1 Dz.



★ **Saucer** FN530 Sandstone
FN506 Limestone
6 1/4"
1 Dz.

(Fits FN504, FN505, FN528 & FN529)



★ **Espresso Cup** FN531 Sandstone
FN507 Limestone
3 1/2 oz.
Dia: 6.5 cm
1 Dz.



★ **Espresso Saucer** FN532 Sandstone
FN508 Limestone
4 1/2"
1 Dz.

(Fits FN531 & FN507)

TECHNOLOGY & MATERIAL



★ ★ ★ ★ ★
DINNERWARE

DUDSON

HARVEST NORSE

NEW



Simplistic Norse, inspired by stripped back Nordic design is available on narrow rimmed plates, coupe rounds and rectangles. Minimal and functional tableware shapes.



NEW

HARVEST NORSE

VITRIFIED CERAMIC



★ **Narrow Rim Plate** FN474 FN486 Norse Grey Norse Linen 6" 1 Dz.



★ **Narrow Rim Plate** FN473 FN485 Norse Grey Norse Linen 7" 1 Dz.



★ **Narrow Rim Plate** FN472 FN484 Norse Grey Norse Linen 8" 1 Dz.



★ **Narrow Rim Plate** FN471 FN483 Norse Grey Norse Linen 9" 1 Dz.



★ **Narrow Rim Plate** FN470 FN482 Norse Grey Norse Linen 10" 1 Dz.



★ **Narrow Rim Plate** FN469 FN481 Norse Grey Norse Linen 11" 1 Dz.



★ **Deep Coupe Plate** FN478 FN490 Norse Grey Norse Linen 10" 1 Dz.



★ **Deep Coupe Plate** FN477 FN489 Norse Grey Norse Linen 11" 1 Dz.



★ **Coupe Bowl** FN476 FN488 Norse Grey Norse Linen 7 1/4" 15 oz. 1 Dz.



★ **Coupe Bowl** FN475 FN487 Norse Grey Norse Linen 9 3/4" 40 oz. 1 Dz.



Organic Rectangular Plate FN479 FN491 Norse Grey Norse Linen 10 5/8" x 6 1/4" 1 Dz.



Organic Rectangular Plate FN480 FN492 Norse Grey Norse Linen 13 5/8" x 6 1/4" 6 pc.

TECHNOLOGY & MATERIAL



★ ★ ★ ★ ★
DINNERWARE



ORGANIC WHITE

NEW



A collection of exclusive shapes. Organic White designs feature a subtle irregular edge and hand-thrown embossment. Manufactured in Dudson's Finest Vitrified body, the collection has the industrial toughness to stand up to every day use in a professional kitchen.

NEW

ORGANIC WHITE

VITRIFIED CERAMIC

DUDSON



Coupe Plate FN879
6 3/8"
1 Dz.



Coupe Plate FN878
9"
1 Dz.



Coupe Plate FN877
10 3/4"
1 Dz.



Coupe Plate FN876
11 5/8"
1 Dz.



Flat Plate FN899
12 1/2"
6 Pcs.



Coupe Bowl FN880
6" 10 1/2 oz.
1 Dz.



Coupe Bowl FN898
8 1/8" 15 1/2 oz.
1 Dz.



Coupe Bowl FN897
9 3/4" 28 oz.
1 Dz.



Coupe Bowl FN884
11" 47 1/2 oz.
1 Dz.



Coupe Wobbly Bowl FN924
11 5/8" 52 7/16 oz.
6 Pcs.



Deep Bowl FN883
6 7/8" x 5 3/4"
16 1/2 oz.
6 Pcs.



Deep Bowl FN923
7 7/8" x 6 5/8"
18 oz.
6 Pcs.



Rectangular Tray FN882
11 1/4" x 7 3/4"
6 Pcs.



Rectangular Tray FN922
13 1/2" x 9 1/8"
6 Pcs.



Coupe Rectangular Plate FN881
10 5/8" x 6 1/4"
1 Dz.



Coupe Rectangular Plate FN885
13 3/4" x 6 1/4"
6 Pcs.

TECHNOLOGY & MATERIAL



DINNERWARE



A handcrafted collection; each piece is individual. Made in England and designed with industrial toughness.



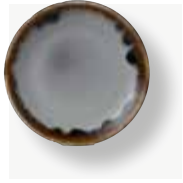

★ Coupe Plate **HN165** Natural
6 1/2" **HB165** Brown
1 Dz. **HL165** Linen
HG165 Green
HBL16 Blue
HI650 Ink
HG650 Grey
FN932 Turquoise
FP088 Plum



★ Coupe Plate **HN217** Natural
8 3/8" **HB217** Brown
1 Dz. **HL217** Linen
HG217 Green
HBL21 Blue
HI867 Ink
HG867 Grey
FN935 Turquoise
FP087 Plum



★ Coupe Plate **HN260** Natural
10 1/4" **HB260** Brown
1 Dz. **HL260** Linen
HG260 Green
HBL26 Blue
HI102 Ink
HG102 Grey
FN930 Turquoise
FP086 Plum



★ Coupe Plate **HN288** Natural
11 1/4" **HB288** Brown
1 Dz. **HL288** Linen
HG288 Green
HBL28 Blue
HI111 Ink
HG112 Grey
FN931 Turquoise
FP085 Plum

NEW



Flat Plate **HN317** Natural
12 1/2"
6 Pcs.

NEW



★ Coupe Plate **HG324** Green
12 3/4" **HB324** Blue
6 Pcs.



★ Coupe Bowl **HN182** Natural
7 1/4" 15 oz. **HB182** Brown
1 Dz. **HL182** Linen
HG182 Green
HBL18 Blue
HI725 Ink
HG725 Grey
FN928 Turquoise
FP090 Plum



★ Coupe Bowl **HN248** Natural
9 3/4" 40 oz. **HB248** Brown
1 Dz. **HL248** Linen
HG248 Green
HBL24 Blue
HI975 Ink
HG975 Grey
FN929 Turquoise
FP089 Plum



★ Deep Coupe **HN255** Natural
Plate **HB255** Brown
10" **HL255** Linen
1 Dz. **HG255** Green
HID10 Ink
HBL25 Blue
HGD10 Grey



★ Deep Coupe **HN281** Natural
Plate **HB281** Brown
11" **HL281** Linen
1 Dz. **HG281** Green
HID11 Ink
HBL11 Blue
HGD11 Grey

NEW



Organic Bowl **HN113** Natural
11 3/8"
6 Pcs.



Trace Organic Bowl **HN253** Natural
9 7/8" **HB253** Brown
1 Dz. **HL253** Linen
HG253 Green
HI978 Ink
HBL38 Blue
HG978 Grey

TECHNOLOGY & MATERIAL



★ ★ ★ ★ ★
DINNERWARE



NEW



Organic Coupe FN941 Turquoise
Bowl
8 1/8" (15 oz.)
1 Dz.

NEW



Organic Coupe FN942 Turquoise
Bowl
9 3/4" (28 oz.)
1 Dz.

NEW



Organic Coupe FN940 Turquoise
Bowl
11" (47 1/2 oz.)
1 Dz.

NEW



Walled Plate HNW86 Natural
8 1/4" **HB867** Blue
6 Pcs. **FP111** Ink

NEW



Walled Plate HNW10 Natural
10 1/4" **HB102** Blue
6 Pcs. **FP112** Ink

NEW



Organic Rectangular FN943 Turquoise
Plate FP091 Plum
10 5/8" x 6 1/4"
1 Dz.



Small Rectangular HN001 Natural
Tray HB001 Brown
11 1/4" x 7 1/2" **HL001** Linen
6 Pcs. **HG001** Green
HIR11 Ink
HBL00 Blue
HGR11 Grey



Large Rectangular HN002 Natural
Tray HB002 Brown
13 1/4" x 9" **HL002** Linen
6 Pcs. **HG002** Green
HIR13 Ink
HBL01 Blue
HGR13 Grey

TECHNOLOGY & MATERIAL





Chefs' Oblong Plate **HN298** Natural
 11 3/4" x 6"
 1 Dz.
HB298 Brown
HL298 Linen
HG298 Green
HIC11 Ink
HBL29 Blue
HGC11 Grey

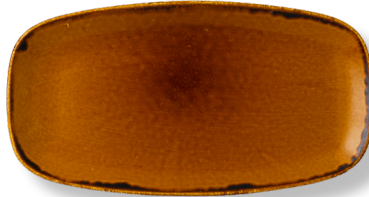

Chefs' Oblong Plate **HN355** Natural
 13 7/8" x 7 3/8"
 6 Pcs.
HB355 Brown
HL355 Linen
HG355 Green
HIC13 Ink
HBL35 Blue
HGC13 Grey

NEW

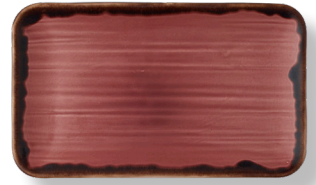

Organic Coupe Rectangular Platter **FN946** Turquoise
FP092 Plum
 13 5/8" x 6 1/4"
 6 Pcs.

NEW



Deep Bowl (16 1/2 oz.) **HND63** Natural
 6 7/8" x 5 3/4" **HB634** Blue
 6 Pcs.

NEW



Deep Bowl (18 oz.) **HND77** Natural
 7 7/8" x 6 5/8" **HB778** Blue
 6 Pcs.



Beverage Pot **FM729** Natural
 13 1/2 oz.
 4 Pcs.



Jug **FM730** Natural
 5 1/2 oz. **HI145** Ink
 4 Pcs.



★ **Mug** **FM739** Natural
 12 oz. **HI113** Ink
 1 Dz.



★ **Cappuccino Cup** **FM732** Natural
 12 oz. (Fits FM736)
 1 Dz.



★ **Coffee/ Tea Cup** **FM733** Natural
 8 oz. **HI227** Ink
 1 Dz. (Fits FM736)



★ **Saucer** **FM736** Natural
 6 1/4" **HI156** Ink
 1 Dz.



★ **Espresso Cup** **FM737** Natural
 3 1/2 oz.
 1 Dz.



★ **Espresso Saucer** **FM738** Natural
 4 1/2"
 1 Dz.



Sauce Dish **FM740** Natural
 3 oz.
 1 Dz.



★ **Sugar Bowl/ Bouillon** **FM741** Natural
 8 oz. (Fits FM736)
 1 Dz.

TECHNOLOGY & MATERIAL





EVO ORIGINS



Evo Origins has the look of real stone. Its textured matte finish will add a new layer of plating possibilities. Mix it with Evo Pearl, Jet or Granite for a striking look.



★ **Coupe Plate** EO165 Natural Grey
6 ½" EB165 Black
1 Dz.



★ **Coupe Plate** EO217 Natural Grey
8 ¾" EB217 Black
1 Dz.



★ **Coupe Plate** EO260 Natural Grey
10 ¼" EB260 Black
1 Dz.



★ **Coupe Plate** EO288 Natural Grey
11 ¼" EB288 Black
1 Dz.



★ **Coupe Bowl** EO182 Natural Grey
7 ¼" 15 oz. EB182 Black
1 Dz.



★ **Coupe Bowl** EO248 Natural Grey
9 ¾" 40 oz. EB248 Black
1 Dz.



Chefs' EO298 Natural Grey
Oblong Plate EB298 Black
11 ¾" x 6" 1 Dz.



Chefs' EO355 Natural Grey
Oblong Plate
13 7/8" x 7 3/8" 6 Pcs.



★ **Deep EO255** Natural Grey
Coupe Plate EB255 Black
10" 1 Dz.



★ **Deep EO281** Natural Grey
Coupe Plate EB281 Black
11" 1 Dz.

TECHNOLOGY & MATERIAL



★ ★ ★ ★ ★
DINNERWARE

DUDSON

EVO



Evo has been designed with the appearance of hand-thrown pottery and its homely charm adds a touch of warmth to any tabletop.



★ Rice Bowl EG105 Granite
4 1/8" x 2" EJ105 Jet
7 oz. EP105 Pearl
2 Dz.

Fits Saucer (6 3/4")



★ Rice Bowl EG178 Granite
7" x 2 1/4" EJ178 Jet
30 oz. EP178 Pearl
2 Dz.



Saucer FM762 Granite
6 3/8" FM754 Jet
2 Dz. FM746 Pearl



Creamer FM763 Granite
2 1/2" x 2 1/2" x 2" FM755 Jet
2 oz. FM747 Pearl
3 Dz.



Mug FM760 Granite (Fits FM762)
T: 3 5/8" M: 5" H: 3 3/8" FM752 Jet (Fits FM754)
11 1/4 oz. FM744 Pearl (Fits FM746)
2 Dz.



Café Au Lait Cup FM761 Granite (Fits FM762)
T: 3 3/4" M: 4 7/8" H: 2 3/4" FM753 Jet (Fits FM754)
10 oz. FM745 Pearl (Fits FM746)
3 Dz.



Tea Cup FM758 Granite (Fits FM762)
T: 3 3/4" M: 4 7/8" H: 2 1/8" FM750 Jet (Fits FM754)
8 oz. FM742 Pearl (Fits FM746)
3 Dz.

NEW



Teapot FN454 Granite
T: 3 1/4" M: 7 7/8" H: 5" B: 5 1/4"
28 oz.
6 pc.

NEW



Sugar Bouillon FN455 Granite
3 3/4" x 2 1/4"
8 oz.
6 pc.



Olive/Tapas Dish FM765 Granite
6 1/4" x 1 1/4" FM757 Jet
(10 oz) FM749 Pearl
2 Dz.



Olive/Tapas Dish FM764 Granite
4 5/8" x 1 1/4" FM756 Jet
(5 oz) FM748 Pearl
4 Dz.



Dip Pot/ Taster Cup FM759 Granite
1 1/2" x 2" FM751 Jet
2 1/2 oz. FM743 Pearl
4 Dz.

TECHNOLOGY & MATERIAL

★ ★ ★ ★ ★ DINNERWARE



2 YEAR
EDGE CHIP
★ 2 ★
WARRANTY

NEW

ACACIA WOOD



FN282*
Acacia Wood MD Rectangle Handled Board
L: 18 ¼" W: 4 ¾"
4 Pcs.



FN283*
Acacia Wood LG Rectangle Handled Board
L: 21 ½" W: 5 ½"
4 Pcs.



FN284*
Acacia Wood Square Handled Board
L: 14 7/8" W: 10"
4 Pcs.

What Items Fit The Acacia Wood?

Dudson- EVO Collection

- Small Tapas Dishes
- Mugs
- Café au Lait Cup
- Teacup
- Small Rice Bowls
- Small Rectangular Trays

Dudson - HARVEST Collection

- Mugs
- Cappuccino Cup
- Coffee Cup
- Sauce Dish
- Sugar Bouillon

Other Side Of Boards Can Be Used To Complement A Table Setting Using
Any Of The Other Dudson Products.

Acacia Wood Also Pairs Well With Our Glassware & Ceramic Dinnerware Accessories.
Reference Page 286

***HAND WASH ONLY**



Introducing wood serveware, exclusively designed to complement the ceramic portfolio. The Acacia Wood items feature a subtle surface texture to create a rustic effect. Double sided designs to allow for flexibility and multiple uses. Food safe and specifically designed for the hospitality industry, Dudson Wood is also sustainable and comes from a 100% renewable source.

★ ★ ★ ★ ★
DINNERWARE



Inspired by the Greek Geode definition, the "shape of the earth" designs feature clean and simple shapes with slight handmade touches.



White Black Grey



• Dinner Plate **FL643** White
 10 3/4" **FK843** Black
 1 Dz. **FK943** Grey



• Salad/Dessert Plate **FL644** White
 8 1/2" **FK844** Black
 1 Dz. **FK944** Grey



• B&B/Side Plate **FL645** White
 6"
 1 Dz.



• Plate **FK788** White
 4" **FK888** Black
 2 Dz. **FK988** Grey



• Bowl **FL646** White
 D: 8 1/2" H: 1 3/4" (32 Oz.) **FK846** Black
 1 Dz. **FK546** Grey



• Bowl **FL647** White
 D: 6" H: 2 1/2" (24 Oz.) **FK847** Black
 1 Dz. **FK947** Grey



• Bowl **FK789** White
 D: 4 3/4" H: 2 3/8" (12 Oz.) **FK889** Black
 2 Dz. **FK989** Grey



• Ramekin **FL648** White
 D: 2 1/2" H: 1 1/4" (1 1/4 Oz.) **FK848** Black
 2 Dz. **FK548** Grey



Mug **FL651** White
 H: 4" T: 3 5/8" M: 5" (12 Oz.) **FK851** Black
 2 Dz. **FK951** Grey



Espresso/Sauce Cup **FK790** White
 H: 2 3/4" T: 2 1/4" B: 1 5/8" M: 2 1/4" (4 Oz.) **FK890** Black
 2 Dz. **FK990** Grey

★ ★ ★ ★ ★
 D I N N E R W A R E

T E C H N O L O G Y & M A T E R I A L

Stoneware







FM550 Soup Plate 8 1/2" (11 oz.)
 T: 8 1/2" H: 1 1/2" 1 Dz.
FM562 Soup Plate 9 1/2" (12 oz.)
 T: 9 1/2" H: 1 1/2" 1 Dz.



FM552 Soup/Pasta Plate 11 3/8" (18 oz.)
 T: 11 3/8" H: 1 5/8" 1 Dz.

NEW



EP777 Deep Oval Bowl 6 1/2" (16 oz.)
 L: 6 1/2" W: 5" H: 2" 1 Dz.



FM557 Chefs' Bowl 8" (30 oz.)
 T: 8" H: 2 1/4" 1 Dz.
FM561 Chefs' Bowl 10 1/2" (52 oz.)
 T: 10 1/2" H: 2 1/4" 3 pcs.

NEW



FN097 Soup Bowl (9 1/2 oz.)
 T: 3 3/4" H: 2 1/4"
 3 Dz.



FM567 Continental Bowl (12 oz.)
 T: 4 5/8" H: 2 1/4"
 3 Dz.



FM537 Bouillon/Sugar (7 3/4 oz.)
 T: 4" H: 2 1/4"
 3 Dz. (Fits FM903)



FM555 Fruit Dish 4 7/8" (5 3/4 oz.)
 T: 4 7/8" H: 1 1/8"
 3 Dz.

NEW



FN808 Teapot w/ Lid (13 oz.)
 L: 7" W: 4 1/2" H: 4 3/4"
 8 Pcs.

NEW



FN809 Creamer No Handle (4 1/2 oz.)
 T: 3" H: 2 3/4" M: 3"
 1 Dz.

★
 ★
 ★
 ★
 ★
 DINNERWARE

TECHNOLOGY & MATERIAL

VITRIFIED
 CERAMIC



C&S
Chef & Sommelier
- FRANCE -

INFINITY



Beautifully translucent and lightweight, yet strong. A favorite of upscale hotels and banquets.



Elegance Redefined. Our Infinity design takes a new turn. The same elegant and durable Bone China now comes in a rimless coupe shape for a more contemporary appeal.



Enjoy coffee service like a fine wine with expertly crafted cups to meet each type of coffee. A one-of-a-kind line offering exceptional experiences for drinking coffee or tea with complementing spatula shaped coffee and demitasse spoons for ladling cappuccino and latte froths. Fine and narrow lips conserve brewing aromas and ergonomic handles add delicacy to the experience.

Spoons can be found on page 237

ARCOROC CANYON RIDGE



Inspired by the geologic nature of canyon colors and shapes with a soft white ridge.



Sand

Blue

Orange



Plate **FJ624** Orange
10 3/8" **FJ524** Sand
18 Pcs. **FJ724** Blue



Plate **FJ525** Sand
8"
3 Dz.



Plate **FJ726** Blue
6 1/2"
3 Dz.



Bowl **FJ628** Orange
8 1/4" (42 Oz.)
1 Dz.



Bowl **FJ629** Orange
6" (15 1/2 Oz.) **FJ529** Sand
3 Dz. **FJ729** Blue



Bowl **FJ630** Orange
4" (5 3/4 Oz.) **FJ730** Blue
4 Dz.



FJ733 Blue Mug
H: 3 5/8" T: 3 1/4" B: 3" M: 4 7/8" (10 3/4 Oz.) 3 Dz.

TECHNOLOGY & MATERIAL



DINNERWARE



A mix of large plates, wooden trays and small containers perfect for grab and go settings, sharing platters and buffet presentations.

NEW



- **N5970** Plate
W: 8 1/4" H: 7/8" 2 Dz.

NEW



- **N5971** Plate
W: 9 3/4" H: 7/8" 2 Dz.

NEW



- **N5973** Plate
W: 12 1/8" H: 3/4" 9 Pcs.

NEW



- **N5969** Plate
W: 7" H: 7/8" 2 Dz.

NEW



- **N5967** Deep Plate
W: 7" H: 1 5/8" 2 Dz.

NEW



- **N5968** Bowl
W: 4 5/8" H: 1 5/8" (10 7/8 oz.) 2 Dz.

TECHNOLOGY & MATERIAL



— ARCOROC SQUARE UP

EXTRA STRONG PORCELAIN

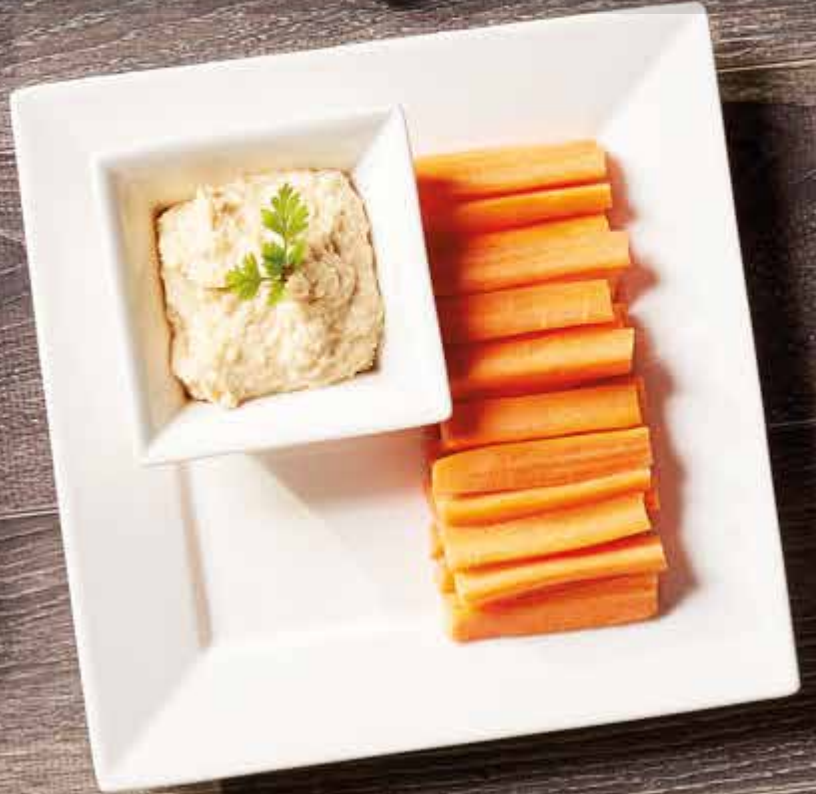

Popular square shapes get a boost from flared sides.



ARCOROC APPETIZER



Accessory pieces that fit everything from hors d'oeuvres to condiments.



L3204 Two Parts Dish
5 1/8" (3/4 oz each compartment) 2 Dz.



L3201 Spoon 3" (1 Oz.) 2 Dz.



L3202 Oval Bowl
3 3/8" (1 1/4 Oz.) 2 Dz.



R0742 Deep Bowl
4" (4 Oz.) 2 Dz.



L3199 Ludico Low Bowl
4 7/8" (1 1/2 Oz.) 2 Dz.



R0740 Deep Oval Bowl
3 7/8" (2 Oz.) 2 Dz.



L3207 Bowl 2 7/8" (2 1/2 Oz.) 2 Dz.
L3208 Bowl 2 1/4" (1 Oz.) 2 Dz.



R0744 Ludico Low Bowl
3 1/4" (2 Oz.) 2 Dz.



R0741 Deep Bowl
3 3/4" (5 Oz.) 2 Dz.



R0743 Spiral Bowl
3 1/4" (3 1/4 Oz.) 2 Dz.



R0738 Spoon
4 1/8" (1/2 oz.) 2 Dz.



R0735 Deep Square Bowl
3 3/8" (4 1/2 Oz.) 2 Dz.



R0739 Organic Bowl
5 5/8" 2 Dz.



R0747 Rimmed Square Bowl
3 7/8" (2 1/4 Oz.) 2 Dz.



L3205 Oval Dish 4 1/8" (1/2 Oz.) 2 Dz.
L3206 Oval Dish 5 7/8" (1 1/4 Oz.) 2 Dz.



L3203 Four Parts Dish
5 5/8" (1 oz each compartment) 2 Dz.

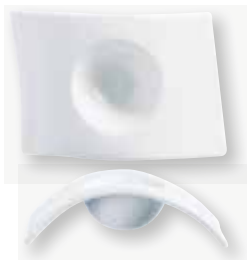

R0745 Wave Rectangular Bowl
4 1/4" (1/2 Oz.) 2 Dz.



R0736 Rectangular Plate
5 5/8" x 2 3/4" 2 Dz.



R0737 Square Plate
3 5/8" 2 Dz.

TECHNOLOGY & MATERIAL





Upcycle is a fantastic addition to add appeal to any table through playful designs.



N5926 Be Bop Bowl
H: 1 7/8" D: 4 1/2" (12 1/2 Oz.) 2 Dz.



N5928 Bag Bowl
H: 3 1/2" T: 3 1/4" M: 3 1/2" (10 Oz.) 2 Dz.



N5933 Jar Bowl
H: 2 3/4" D: 2 1/2" (4 Oz.) 2 Dz.



N5932 Jar Bowl
H: 3 1/4" D: 2 1/2" (6 3/4 Oz.) 2 Dz.

TECHNOLOGY & MATERIAL



DINNERWARE

ARCOROC RONDO



Wide rims and deep coupe plates feature soft concentric rings.



S1506 B&B/Side Plate 6 3/4" 3 Dz.
S1504 Salad/Dessert Plate 8 5/8" 3 Dz.



S1503 Brunch Plate 9 7/8" 3 Dz.
S1502 Dinner Plate 11" 2 Dz.
S1501 Service Plate 12" 1 Dz.



S1508 Coupe Bowl 7" (14 Oz.) 3 Dz.
S1512 Coupe Bowl 9" (30 Oz.) 3 Dz.



S1509 Coupe Deep Plate 12" 1 Dz.



S1507 Rim Soup/Pasta Bowl
9 1/4" (8 Oz.) 2 Dz.



S1550 Fruit/Side Dish
4 3/4" (4 Oz.) 3 Dz.



S1530 Bouillon Cup (fits S1533)
H: 2 5/8" M: 3 3/4" (11 Oz.) 2 Dz.



S1534
Grapefruit/Cereal Bowl
H: 2 5/8" M: 4 3/8" (17 Oz.)
3 Dz.



S1517 Small Creamer
H: 3 1/8" T: 2" M: 4 3/8" (4 1/2 Oz.)
2 Dz.



S1518 Large Creamer
H: 3 3/8" T: 2 1/2" M: 5 1/8" (8 1/2 Oz.)
1 Dz.



S1521 Teapot with Cover
6 3/4" (20 Oz.)
1 Dz.



S1535 Coffee Mug
H: 3 1/2" T: 3 1/8" M: 4 3/8" (10 Oz.) 1 Dz.



S1538 Coffee/Teacup H: 2 1/2" T: 3 1/2" M: 4 5/8" (8 Oz.) 2 Dz.
S1533 Saucer/Bouillon Saucer (fits S1530) 6 3/4" 2 Dz.



S1528 Coffee/Teacup (Tall) H: 3 1/4" T: 3 1/2" M: 4 3/8" (8 Oz.) 2 Dz.
S1533 Saucer/Bouillon Saucer (fits S1530) 6 3/4" 2 Dz.

TECHNOLOGY & MATERIAL







S0606 B&B/Side Plate 6 1/2" 3 Dz.
S0604 Salad/Dessert Plate 8 1/4" 3 Dz.



S0603 Brunch Plate 9 1/4" 2 Dz.
S0602 Dinner Plate 11" 2 Dz.



S0638 Coffee/Teacup H: 2 1/2" T: 3 1/4" M: 4 1/2" (8 Oz.) 2 Dz.
S0633 Saucer/Bouillon Saucer (fits S0630) 6" 2 Dz.



S0628 Coffee/Teacup H: 4 1/2" T: 3 1/4" M: 4 1/2" (7 Oz.) 2 Dz.
S0633 Saucer/Bouillon Saucer (fits S0630) 6" 2 Dz.



S0630 Bouillon Cup/Open Sugar (fits S0633) H: 3 3/4" M: 3 3/4" (9 Oz.) 2 Dz.



S1916 Sugar Caddy H: 2 1/8" L: 3 5/8" W: 2 3/8" 1 Dz.

TECHNOLOGY & MATERIAL



ARCOROC CANDOUR COUPES



Simply Smart. In Extra Strong Porcelain, Candour is a go-to favorite with customers for its long lasting resistance. Now with a rimless design, elegance has never seemed so simple.



FH288 Coupe B&B Plate 6 1/2" 2 Dz.

FH286 Coupe Salad/Dessert Plate 8 1/8" 2 Dz.

FH285 Coupe Dinner/Banquet Plate 10 3/4" 2 Dz.

NEW FM382 Coupe Plate 11 1/2" 1 Dz.



FH621 Coupe Deep Soup Plate 8 1/8" (24 1/2 Oz.) 2 Dz.



FH608 Coupe Brunch Plate 9" 2 Dz.



FH609 Coupe Oval Platter 10 3/8" 1 Dz.

FH610 Coupe Oval Platter 12 1/4" 1 Dz.

FH611 Coupe Oval Platter 14 1/4" 1 Dz.



FH289 Coupe Bowl 9 1/4" (101 1/2 Oz./3L) 6 Pcs.



FH287 Coupe Bowl 6 1/8" (20 Oz.) 2 Dz.



FH615 Mug H: 4 1/8" T: 3 3/8" M: 4 1/2" (14 Oz.) 2 Dz.



FH614 Mug H: 3 5/8" T: 3 1/8" M: 4 3/8" (10 1/2 Oz.) 2 Dz.

TECHNOLOGY & MATERIAL



★ ★ ★ ★ ★
DINNERWARE

ARCOROC CANDOUR

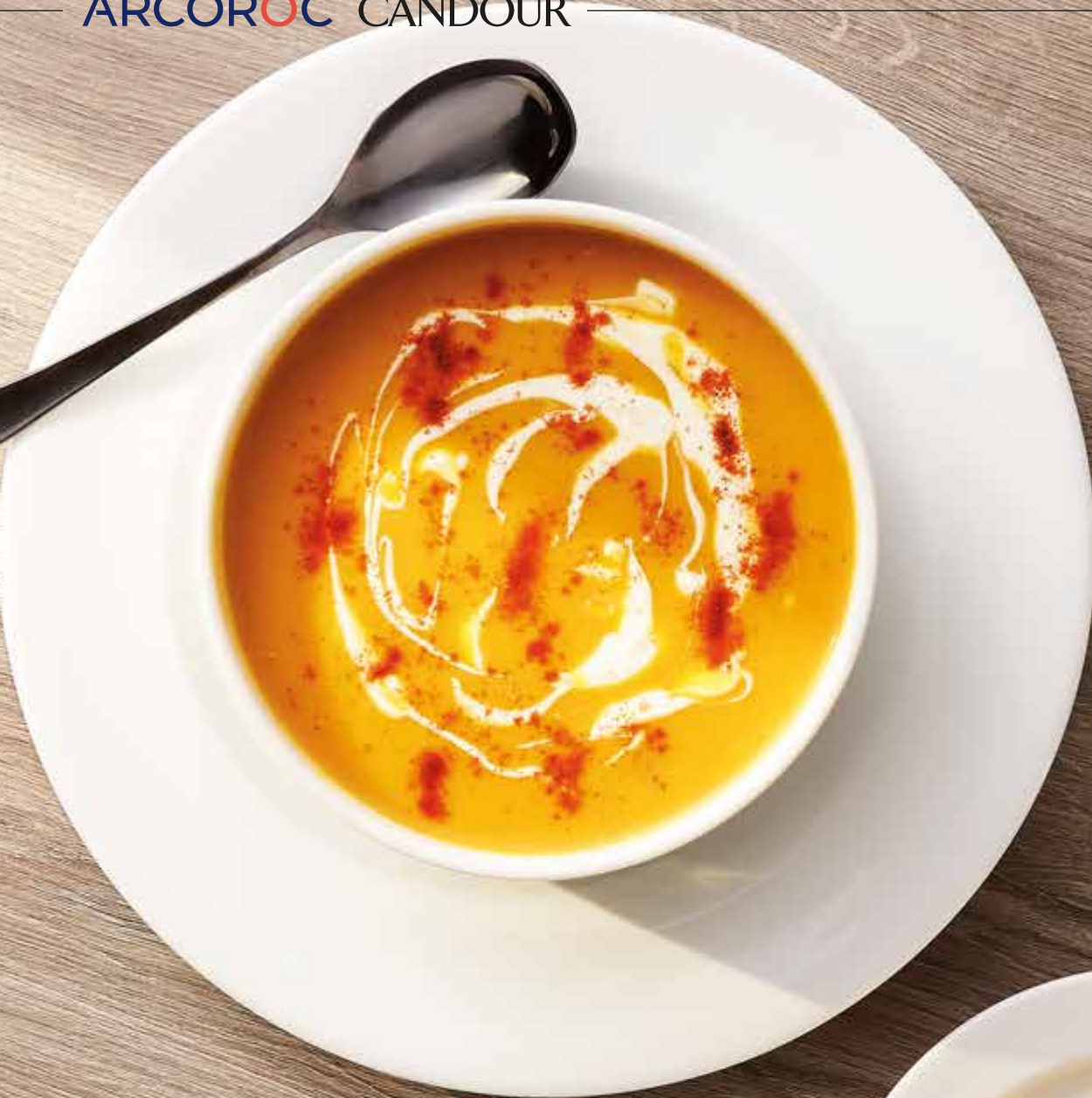

Wide rims, flat profiles and space-saving stackability. Easily pairs with the Vintage collection.



R0860 Oval Platter L: 13 1/8" W: 9 3/8" 8 Pcs.



R0806 B&B Plate 6 1/4" 2 Dz.

R0805 Side Plate 7 3/8" 2 Dz.

R0804 Salad Plate 8 1/2" 2 Dz.

R0803 Brunch Plate 10" 2 Dz.

R0802 Banquet Plate 10 1/2" 1 Dz.

R0801 Dinner Plate 11 1/2" 1 Dz.

R0811 Service Plate 12" 1 Dz.



R0809 Pasta Bowl 11 3/4" (18 1/2 Oz.) 1 Dz.

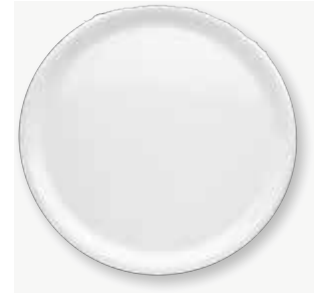

NEW FM381 Pizza Plate 12 1/2" 1 Dz.



R0807 Soup Plate 8 3/4" (12 Oz.) 1 Dz.



R0840 Soup Bowl (fits R0833) 3 3/4" (9 Oz.) 2 Dz.



R0830 Soup Bowl 4 1/2" (12 1/2 Oz.) 2 Dz.



R0852 Bowl 2 3/4" (2 1/4 Oz.) 2 Dz.

R0851 Bowl 4" (8 Oz.) 2 Dz.

R0850 Bowl 5 1/8" (16 3/4 Oz.) 2 Dz.

R0849 Bowl 6 1/4" (33 3/4 Oz.) 2 Dz.



R0839 Cup H: 2 1/4" W: 3 3/4" (9 3/4 Oz.) 2 Dz.

R0833 Saucer (Also fits R0840, R0830) 6 1/2" 2 Dz.



R0835 Mug H: 3" W: 3 1/2" (11 Oz.) 2 Dz.



R0817 Creamer H: 2 3/4" W: 2 1/8" (3 1/2 Oz.) 16 Pcs.



R0819 Teapot H: 4 1/4" W: 3 1/2" (15 Oz.) 8 Pcs.



R0882 Vase H: 5 1/2" W: 3" (6 1/4 Oz.) 16 Pcs.

TECHNOLOGY & MATERIAL



ARCOROC CANDOUR CIRRUS



Eye-catching swept embossment designs create the perfect harmony between refined beauty and long lasting resistance for high volume operations.



FK763 Service Plate 12" 1 Dz.



FK764 Dinner Plate 11 1/2" 1 Dz.



FK765 Banquet Plate 10 1/2" 1 Dz.



FK766 Brunch Plate 10" 2 Dz.



FK767 Salad Plate 8 1/2" 2 Dz.



FK768 Side Plate 7 3/8" 2 Dz.



FK769 B&B Plate 6 1/4" 2 Dz.



FK774 Pasta Bowl 11 3/4" (18 1/2 Oz.) 1 Dz.



FK770 Soup Bowl 8 3/4" (12 Oz.) 1 Dz.



FK777 Cup H: 2 1/4" W: 3 3/4" (9 3/4 Oz.) 2 Dz.
FK775 Saucer 6 1/2" 2 Dz.

TECHNOLOGY & MATERIAL



DINNERWARE ★★★★★

ARCOROC CANDOUR AZURE



Create a unique color impact with blue and white pattern combinations.
Complement the line as an accent piece with white bodied Candour or Louison glass dinnerware.

ARCOROC VINTAGE



Scooped rims and deep-welled platters create timeless appeal. With the same body color as Candour, all shapes easily work together.



R0906 B&B Plate 6 3/4" 2 Dz.
R0905 Side Plate 7 1/4" 2 Dz.
R0904 Salad Plate 8" 2 Dz.
R0903 Brunch Plate 9 3/4" 2 Dz.
R0902 Dinner Plate 10 1/2" 1 Dz.
R0901 Service Plate 12 1/4" 1 Dz.



R0907 Soup Plate 9 1/2" (10 Oz.) 1 Dz.



R0908 Soup/Cereal Bowl 7" (16 3/4 Oz.) 2 Dz.



R0960 Rectangular Dish L: 13" W: 7 1/4" 8 Pcs.
R0959 Rectangular Dish L: 14 1/2" W: 7 1/2" 8 Pcs.



R0968 Rectangular Dish L: 11" W: 9 1/4" 1 Dz.



R0950 Square Bowl 4 1/2" (12 1/2 Oz.) 2 Dz.



R0947 Bowl 8 3/4" (69 Oz.) 16 Pcs.



R0917 Creamer
 H: 4 1/2" W: 2 1/8" (4 Oz.) 16 Pcs.



R0918 Jug
 H: 6 5/8" W: 3 3/8" (12 1/2 Oz.) 8 Pcs.



R0919 Teapot
 H: 4 1/4" W: 4 1/8" (12 Oz.) 8 Pcs.



R0926 Cup H: 2" W: 2 1/2" (3 Oz.) 2 Dz.
R0931 Saucer 4 3/4" 2 Dz.



R0929 Cup H: 2 3/4" W: 4" (11 3/4 Oz.) 2 Dz.
R0933 Saucer 7" 2 Dz.



R0928 Cup H: 2 1/2" W: 3 1/2" (8 Oz.) 2 Dz.
R0932 Saucer 5 3/4" 2 Dz.

TECHNOLOGY & MATERIAL



DINNERWARE ★★★★★



Basic, essential and complete. The most common shapes, styles and sizes of reliable dinnerware at a value price point.



FJ776 Coupe B&B Plate 6 1/4" 3 Dz.

FJ775 Coupe Salad/Dessert Plate 8 1/4" 2 Dz.

FJ774 Coupe Brunch Plate 9" 2 Dz.

FJ772 Coupe Dinner Plate 10 1/4" 18 Pcs.



FJ816 B&B/Side Plate 7" 4 Dz.

FJ815 Salad Plate 8" 3 Dz.

FJ812 Banquet Plate 10 1/8" 18 Pcs.

FJ811 Dinner Plate 10 5/8" 18 Pcs.

FJ809 Service Plate 12" 1 Dz.



FJ778 Coupe Oval Platter 10 1/4" 2 Dz.

FJ777 Coupe Oval Platter 12 1/4" 18 Pcs.



FJ825 Oval Platter 13 1/2" x 10 1/4" 1 Dz.

FJ826 Oval Platter 15 1/2" x 10 3/4" 6 Pcs.



FJ824 Mid Rim Oval Platter 11" x 8 1/4" 18 Pcs.



FJ831 Square Coupe Platter 13 1/4" x 8 3/8" 1 Dz.



FJ830 Flatbread Plate 12 1/4" x 5 7/8" 1 Dz.



FJ827 Canoe Plate 17 1/2" x 4" (15 1/2 Oz.) 1 Dz.



FJ779 Casserole D: 5 7/8" M: 7 1/2" H: 1 1/8" 2 Dz.



FJ823 Oval Baker 6 1/8" x 4 1/4" (10 Oz.) 1 Dz.



FJ822 Rarebit 8 1/4" x 5 1/8" (15 Oz.) 1 Dz.



FJ819 Side Bowl 7 7/8" (26 Oz.) 18 Pcs.

FJ818 Large Bowl 10" (49 Oz.) 1 Dz.



FJ821 French Onion Soup Crock Bowl
H: 2 1/8" T: 5 1/4" M: 6" (12 Oz.)
2 Dz.



FJ820 Bouillon Cup
H: 2 1/4" M: 3 3/4" (8 Oz.)
3 Dz.



FJ832 Coffee Cup H: 2 1/2" T: 3 3/8" M: 4 1/2" (8 Oz.) 2 Dz.

FJ833 Coffee Saucer 6 1/8" 2 Dz.



FJ834 Coffee Mug
H: 4 1/4" T: 3 5/8" M: 5" (14 1/2 Oz.)
2 Dz.

TECHNOLOGY & MATERIAL



DINNERWARE

ARCOROC OPAL DINNERWARE



PLATES

INTENSITY COLLECTION



G4394/V1540 B&B Plate 6 1/4" 2 Dz.



G4391/V1539 Salad Plate 8" 2 Dz.
H7496/V1537 Plate 9 1/2" 2 Dz.



P3964/V1536 Banquet Plate 10" 1 Dz.



P3962/V1653 Dinner Plate 10 3/4" 1 Dz.

RESTURANT WHITE COLLECTION



58621 Narrow Rim B&B Plate 6" 2 Dz.
57974 Narrow Rim Side Plate 7 1/2" 2 Dz.
57975 Narrow Rim Lunch Plate 9 1/4" 2 Dz.
N6393 Narrow Rim Dinner Plate 10 1/4" 1 Dz.



L6850 Deep Plate 9 3/4" 1 Dz.



22506 Wide Rim B&B Plate 6" 2 Dz.
22530 Wide Rim Side Plate 7 1/2" 2 Dz.
22522 Wide Rim Lunch Plate 9 3/8" 2 Dz.
24742 Wide Rim Dinner Plate 10" 2 Dz.

EVOLUTIONS WHITE COLLECTION



N9362 Coupe Dessert Plate 7 1/4" 2 Dz.



N9361 Coupe Plate 10" 2 Dz.
N9360 Coupe Plate 10 5/8" 2 Dz.



N9411 Coupe Soup 7 3/4" (26 1/4 Oz.) 2 Dz.
N9408 Deep Plate 10 1/8" (40 1/2 Oz.) 2 Dz.

TECHNOLOGY & MATERIAL



ARCOROC OPAL DINNERWARE

SPECIALTY

EVOLUTIONS WHITE COLLECTION



N9364 Oval Platter 9 3/4" x 13" 1 Dz.



N9404 Rectangular Plate 8 1/4" x 7 1/4" 2 Dz.

N9403 Rectangular Plate 11" x 9" 1 Dz.

N9402 Rectangular Platter 13 3/4" x 9 1/4" 1 Dz.



N9406 Pizza Plate 12 1/2" 1 Dz.



N9407 Steak Plate 11 3/4" x 10" 1 Dz.



N9405 Pasta Plate 11 1/8" (38 3/4 Oz.) 1 Dz.

RESTAURANT WHITE COLLECTION



P3967 Oval Platter 11 1/2" 1 Dz.

67107 Oval Platter 12 1/2" 2 Dz.

NEW



P3979 Compartment Plate 10" 1 Dz.



29337 Hospital Heat System Plate 8 3/4" 2 Dz.



22514 Rim Soup 9" (23 Oz.) 2 Dz.



INTENSITY COLLECTION

G4396/V1538 Rim Soup/Pasta Bowl 8 1/2" (11 3/4 Oz.) 2 Dz.

TECHNOLOGY & MATERIAL



★ ★ ★ ★ DINNERWARE

BOWLS

EVOLUTIONS WHITE COLLECTION



N9397 Ramekin 3 1/2" (6 1/4 Oz.) 3 Dz.



N9396 Bowl 4 5/8" (13 1/2 Oz.) 3 Dz.

N9395 Bowl 5 5/8" (25 1/4 Oz.) 2 Dz.

N9365 Bowl 7" (33 3/4 Oz.) 1 Dz.

N9363 Bowl 8 1/4" (71 1/4 Oz.) 1 Dz.



N9401 Service Dish 7" (1.3 L) 2 Dz.

N9399 Service Dish 10" (2.8 L) 6 Pcs.

N9398 Service Dish 11 3/4" (4 L) 3 Pcs.

NEW



• **P9773** Bowl 6 1/16" (20 1/4 Oz.) 1 Dz.

• **P9772** Bowl 8 1/4" (32 Oz.) 1 Dz.

• **P9771** Bowl 9 7/8" (47 Oz.) 1 Dz.

RESTAURANT WHITE COLLECTION



25285 Fruit Bowl 4 3/4" (3 1/2 Oz.) 3 Dz.

25293 Grapefruit Bowl 6 1/4" (7 Oz.) 3 Dz.



• **43319** Bowl 4 3/4" (10 1/2 Oz.) 3 Dz.



• **28891** Double Handled Bowl

H: 2 1/4" M: 4" (10 1/2 Oz.) 2 Dz.



50061 Multi-Usage Bowl 6 1/4" (15 Oz.) 2 Dz.

BEVERAGE

RESTAURANT WHITE COLLECTION



• **64733** Mug H: 3 1/2" M: 4 3/8" (10 Oz.) 3 Dz.



• **36140** Mug H: 3 1/2" T: 2 3/4" B: 2 1/2" M: 4" (8 Oz.) 3 Dz.



• **25269** Tall Cup H: 2 7/8" M: 3" (7 1/2 Oz.) 4 Dz.

22712 Saucer 5 7/8" 3 Dz.



• **22662** Cup (2 3/4 Oz.) 4 Dz.

22670 Saucer 4 1/4" 4 Dz.



• **14611** Cup H: 2 3/4" M: 3 1/4" (8 Oz.) 3 Dz.

22712 Saucer 5 7/8" 3 Dz.

TECHNOLOGY & MATERIAL





Mix and match the refinement of Granite Evolutions.

★ ★ ★ ★ DINNERWARE



P1122 Coupe Dinner Plate 10 5/8" 2 Dz.



P1123 Coupe Dinner Plate 10" 2 Dz.



P1125 Coupe Dessert Plate 7 1/4" 2 Dz.



P1124 Coupe Soup Plate 7 3/4" (26 1/4 Oz.) 2 Dz.

TECHNOLOGY & MATERIAL



NEW

EVOLUTIONS

BLACK

ARCOROC



P1131 Coupe Salad/Dessert Plate 7 ¼" 2 Dz.

P1129 Coupe Plate 10" 2 Dz.

P1128 Coupe Plate 10 5/8" 2 Dz.



P1140 Steak Plate 11 ¾" x 10" 1 Dz.



P1139 Pizza Plate 12 ½" 1 Dz.



P1141 Deep Plate (40 ½ Oz.) 10 5/8" 2 Dz.



P1130 Coupe Soup Plate 7 ¾" (26 ¼ Oz.) 2 Dz.

P1138 Coupe Pasta Plate 11" (38 ¾ Oz.) 1 Dz.



P1137 Rectangular Plate 11"x9" 1 Dz.

Create a harmonious presentation with Evolutions Black.



★
★
★
DINNERWARE

TECHNOLOGY & MATERIAL



ARCOROC BRUSH



Blue Orange Yellow Green Blue Jean Cherry

Brush up on style with a range of colors ideal for serving menus with dietary restrictions.



Dinner Plate **P3945** Blue
10" **P3949** Orange
1 Dz. **P3951** Yellow
P3948 Green
P3946 Blue Jean
P3947 Cherry



Side Plate **49150** Blue
7 1/2" **49138** Orange
2 Dz. **49139** Yellow
49142 Green
H3608 Blue Jean
H2685 Cherry



Lunch Plate **H3607** Blue Jean
9 1/4" **H2684** Cherry
2 Dz.



B&B Plate **H3609** Blue Jean
6" **H2686** Cherry
2 Dz.



Soup Plate **H3610** Blue Jean
9" (23 Oz.)
2 Dz.



*Footed Bowl **P5862** Blue
5 1/8" (17 1/4 Oz.)
3 Dz. **P5866** Orange
P5860 Yellow
P5864 Green
P5865 Blue Jean
P5849 Cherry



Fruit Bowl **H3611** Blue Jean
4 5/8" (3 1/2 Oz.)
3 Dz. **H2691** Cherry



* Bowl **H3615** Blue Jean
4 3/4" (10 1/2 Oz.)
3 Dz. **H2779** Cherry



*Mug **P5843** Blue
H: 3 1/2" (8 Oz.)
3 Dz. **P5845** Orange
P5846 Yellow
P5844 Green
P5847 Blue Jean
P5842 Cherry

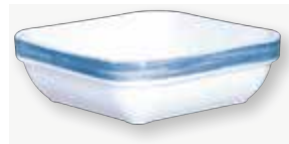

* Square Dish **H3612** Blue Jean
4 1/4" (8 Oz.)
2 Dz.

TECHNOLOGY & MATERIAL



* Denotes a new design

★
★
★

DINNERWARE

ARCOROC SMART CUISINE

NEW

SMART CUISINE
250°C/475°F

Oven Glass
Extra Light - Extra Resistant



Same key components as Opal with a different tempering process to allow for oven use. Most oven ware products are limited in design, too heavy or too fragile and chips easily but not SMART CUISINE. Design offers easy to grip handles and deep wells for dishes with sauces. This new collection of oven to tableware couples durability and style.



N3295
Ramekin (9 ¼ oz.)
H: 4 ¾"
1 Dz.



P0310
Crème Brulee Dish (9 ½ oz.)
H: 5 ½"
1 Dz.



P4025
Square Dish (33 ¾ oz.)
L: 8" W: 8" H: 1 ¾"
8 pcs.



P8332
Rectangular Dish (61 oz.)
L: 11 ¾" W: 9" H: 2"
6 pcs.



P0887
Oval Dish (17 oz.)
L: 8 ¼" W: 5 ½" H: 1 ½"
6 pcs.



P0886
Oval Dish (30 oz.)
L: 9 ¾" W: 6" H: 2"
6 pcs.

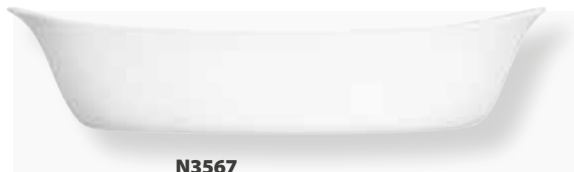

N3567
Oval Dish (44 oz.)
L: 11 ¾" W: 6 ⅝" H: 2 ½"
6 pcs.

TECHNOLOGY & MATERIAL



ARCOROC KEEP N BOX



Highly shock resistant, hygienic (glass barrier against bacteria), transparent base to quickly identify food stored inside. No degradation of the taste, the smell, or the composition of food. Reusable, microwavable, & safe for an industrial dishwasher.

NEW

KEEP N BOX

FULLY TEMPERED

ARCOROC



LIDS ONLY

FN235
Lid P5522 (12 3/4 oz.) 38 CL
1 Dz.

FN236
Lid P5521 (25 1/2 oz.) 76 CL
1 Dz.

FN237
Lid P5520 (41 1/4 oz.) 122 CL
1 Dz.

FN238
Lid P5517 (41 1/4 oz.) 122 CL
1 Dz.

FN239
Lid P5516 (66 1/2 oz.) 197 CL
1 Dz.

FN240
Lid P5523 (31 oz.) 92 CL
1 Dz.

P5522
Square Box (12 3/4 oz.) 38 CL
L: 4 7/8" W: 4 7/8" H: 2 1/8"
6 Pcs.

P5521
Square Box (25 1/2 oz.) 76 CL
L: 6" W: 6" H: 2 1/2"
6 Pcs.



P5517
Rectangular Box 8 1/4" (41 1/4 oz.) 122 CL
L: 8 1/4" W: 6" H: 2 1/2"
6 Pcs.

P5516
Rectangular Box 9 1/2" (66 1/2 oz.) 197 CL
L: 9 1/2" W: 7" H: 2 3/4"
6 Pcs.



P5523
Round Bowl 7" (31 oz.) 92 CL
H: 2 3/4"
6 Pcs.



P5520
Square Box (41 1/4 oz.) 122 CL
L: 7" W: 7" H: 2 3/4"
6 Pcs.

TECHNOLOGY & MATERIAL



GLASS DINNERWARE

ARCOROC SO URBAN



So Urban is a durable product with air tight lids to ensure NO leaking, which makes this the perfect product for take-out, delivery & grab and go.

LDPE (Polyethylene) lids are Safe and Reusable!

NEW

SO URBAN

FULLY TEMPERED

ARCOROC



STACKS PERFECTLY WITH OR WITHOUT LIDS



Q1758
Bowl 4 1/4" (8 1/4 Oz.) 25 CL
(Sold Together/ Non-Assembled)
2 Dz.



Q1757
Bowl 4 1/4" (12 1/2 Oz.) 37 CL
(Sold Together/ Non-Assembled)
2 Dz.



Q1752
Bowl 5 1/2" (19 1/2 Oz.) 58 CL
(Sold Together/ Non-Assembled)
2 Dz.



Q0620
Bowl 5 1/2" (27 Oz.) 80 CL
(Sold Together/ Non-Assembled)
2 Dz.

LID & BASE SOLD SEPARATELY



Q5214
Onctuous (7 1/2 Oz.) 22 CL
2 Dz.



Q5217
Lid for Onctuous
2 Dz.



Q1762
Bowl 4 1/4" (8 1/4 Oz.) 25 CL
2 Dz.



Q1753
Bowl 4 1/4" (12 1/2 Oz.) 37 CL
2 Dz.



Q3007
Lid 4 1/4" (fits Q1753&Q1762)
2 Dz.



Q1750
Bowl 5 1/2" (19 1/2 Oz.) 58 CL
2 Dz.



Q1745
Bowl 5 1/2" (27 Oz.) 80 CL
2 Dz.



Q3006
Lid 5 3/4" (fits Q1750 & Q1745)
2 Dz.

TECHNOLOGY & MATERIAL



★ ★ ★ GLASS DINNERWARE

ARCOROC ARCADE BOWLS

FULLY TEMPERED

Elegantly fluted bowls for all your serving needs.



00556 Bowl 5" (11 Oz.) 12 Dz.
M0090 Bowl 6" (22 Oz.) 2 Dz.



N7945 Bowl 7" (38 Oz.) 1 Dz.
43830 Bowl 8" (48 Oz.) 1 Dz.
N2608 Bowl 9" (72 Oz.) 1 Dz.

ARCOROC STACK BOWLS

FULLY TEMPERED

Prep and serve bowls in multiple sizes now available with white plastic lids for added safety measures.



- **E9155** Bowl 2 1/2" (1 1/4 Oz.) 3 Dz.
- **E9156** Bowl 3" (2 3/4 Oz.) 3 Dz.
- **E9157** Bowl 3 1/2" (5 Oz.) 3 Dz.
- **E9158** Bowl 4 1/8" (7 1/2 Oz.) 3 Dz.
- **E9159** Bowl 4 3/4" (12 Oz.) 3 Dz.



- **10027** Bowl 6 5/8" (39 Oz.) 2 Dz.
- **09994** Bowl 10 1/4" (144 Oz.) 6 Pcs.

TECHNOLOGY & MATERIAL



NEW

STACK BOWL W/ LID

FULLY TEMPERED

ARCOROC



The Stack Bowl is versatile in size and functional in design. The stacking ledge is optimal for space saving and easy storage. The BPA-free lid is an easy answer to keeping your patrons safe and reducing the chance for contamination- or even to go!



LIDS SOLD SEPARATELY



Q2984 Lid (4 3/4") 3 Dz. Fits E9159



Q2985 Lid (5 1/2") 3 Dz. Fits E9160
Q2983 Lid (6 5/8") 3 Dz. Fits 10027



E9159 Bowl 4 3/4" (12 Oz.) 3 Dz.



E9160 Bowl 5 1/2" (21 Oz.) 3 Dz.
10027 Bowl 6 5/8" (39 Oz.) 3 Dz.

TECHNOLOGY & MATERIAL



GLASS DINNERWARE

ARCOROC LOUISON



Elegant designs tap into vintage trends. Features clean lines and beaded textures.



L6084 Large Dinner Plate 10 1/2" 1 Dz.



L4210 Brunch Plate 9 3/4" 1 Dz.



L6350 Dessert Plate 7 1/2" 1 Dz.



N8804 Platter 12 1/2" 6 Pcs.



N2420 Bowl 10 1/4" (90 Oz.) 6 Pcs.



L6498 Soup Bowl 7 3/4" (35 Oz.) 1 Dz.



L7422 Multipurpose Bowl 6 1/4" (19 1/2 Oz.) 1 Dz.

TECHNOLOGY & MATERIAL



GLASS DINNERWARE ★★

ARCOROC

FLEUR

FULLY TEMPERED

Our iconic petal shape adorns banquets and buffets everywhere.

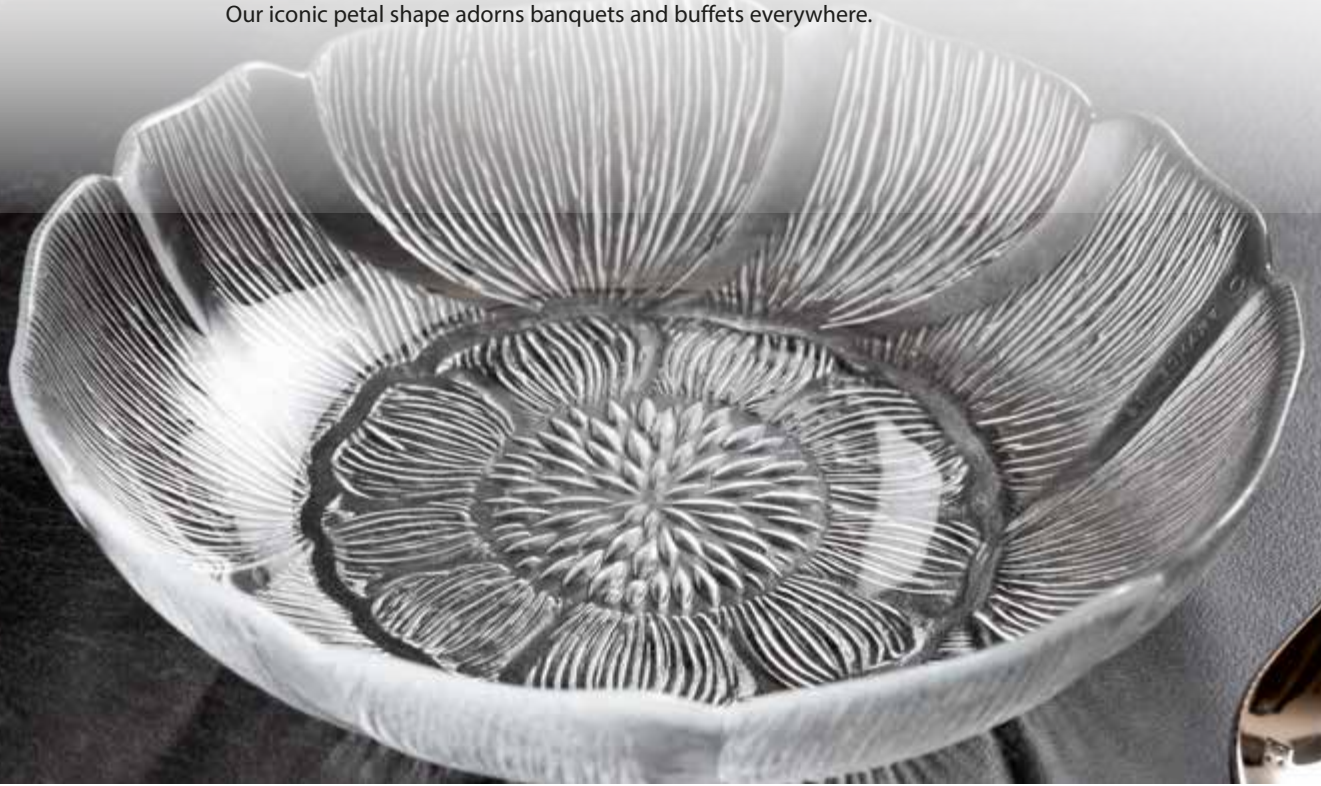

GLASS DINNERWARE



- H4120** Bowl 5" (10 ½ Oz.) 2 Dz.
- E8883** Bowl 7" (32 Oz.) 6 Pcs.
- D9070** Bowl 9" (70 Oz.) 4 Pcs.
- 06626** Bowl 10 ½" (3 ½ Qt. - 112 Oz.) 6 Pcs.



J0226 Soup/Deep Salad Bowl 8" (15 Oz.) 3 Dz.



J0232 Dessert Plate 7 ½" 3 Dz.
J0856 Dinner Plate 9" 3 Dz.



08781 Compote 5 ¾" (10 Oz.) 4 Dz.

TECHNOLOGY & MATERIAL



Indentations around the rim offer a vintage feel.



01166 Dessert Plate 6" 3 Dz.
01158 Salad Plate 7 1/2" 3 Dz.
01141 Dinner Plate 9 1/8" 3 Dz.

GLASS COFFEE MUGS

FULLY TEMPERED



37684
 Irish Coffee (8 1/2 Oz.)
 H: 5 1/2" T: 3"
 B: 2 1/16" M: 3 1/2"
 2 Dz.



11874
 Irish Coffee (10 Oz.)
 H: 5 5/8" T: 2 3/4"
 B: 2 3/4" M: 4"
 2 Dz.



53403
 Irish Coffee (10 Oz.) *Non-Tempered*
 H: 5 5/8" T: 2 3/4"
 B: 2 3/4" M: 4"
 2 Dz.



61875
 Mug (8 1/2 Oz.)
 H: 3 1/2" T: 2 5/16"
 B: 2 7/16" M: 4 1/16"
 3 Dz.



D9219
 Nordic Mug (12 1/2 Oz.)
 H: 3 3/4" T: 3 1/4"
 B: 3 1/2" M: 4 7/8"
 2 Dz.



73442
 Black Mug (10 1/2 Oz.)
 H: 3 1/16" T: 3 1/8"
 B: 3" M: 4 3/8"
 1 Dz.

GLASS DINNERWARE

TECHNOLOGY & MATERIAL





L6687
Maeva Dot Dessert Bowl (6 ¾ Oz.)
H: 2 ⅝" T: 4"
B: 2" M: 4"
2 Dz.



L6688
Maeva Dot Dessert Bowl (11 ¾ Oz.)
H: 3 ¼" T: 4 ¾"
B: 2 ¼" M: 4 ¾"
2 Dz.



L6689
Maeva Diamant Dessert Bowl (6 ¾ Oz.)
H: 2 ⅝" T: 4"
B: 2" M: 4"
2 Dz.



L6690
Maeva Diamant Dessert Bowl (11 ¾ Oz.)
H: 3 ¼" T: 4 ¾"
B: 2 ¼" M: 4 ¾"
2 Dz.



L6691
Maeva Vintage Dessert Bowl (6 ¾ Oz.)
H: 2 ⅝" T: 4"
B: 2" M: 4"
2 Dz.



L6692
Maeva Vintage Dessert Bowl (11 ¾ Oz.)
H: 3 ¼" T: 4 ¾"
B: 2 ¼" M: 4 ¾"
2 Dz.



D3612
Versatile Long Oval Bowl (8 ¼ Oz.)
7 ⅝"
2 Dz.



R0748 Rectangular Plate 10 ¼" x 4 ¾" 2 Dz.



58012
 Palmier Dessert (12 1/2 Oz.)
 H: 7 7/8" T: 4 3/4"
 B: 3 1/4" M: 4 3/4"
 2 Dz.



58010
 Palmier Dessert (7 Oz.)
 H: 3 15/16" T: 4 7/8"
 B: 2 3/4" M: 4 7/8"
 2 Dz.



43121
 Swirl Optic Dessert (12 Oz.)
 H: 3 3/4" T: 4 5/8"
 B: 3 1/4" M: 4 5/8"
 2 Dz.



50998
 Swirl Optic Dessert (7 Oz.)
 H: 3 1/8" T: 3 7/8"
 B: 2 3/4" M: 3 7/8"
 2 Dz.

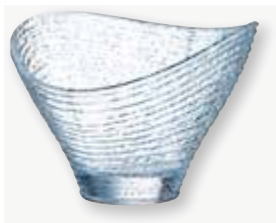

L6756
 Jazzed Glass Bowl (8 1/4 Oz.)
 H: 3 3/4" T: 5 5/8"
 B: 2 1/8" M: 5 5/8"
 1 Dz.



L6753
 Jazzed Glass Bowl (8 1/4 Oz.)
 H: 3 3/4" T: 5 5/8"
 B: 2 1/8" M: 5 5/8"
 1 Dz.

FLATWARE

Designs You Can Trust

We craft our flatware for high volume foodservice with the finest materials and highest standards. Each piece is perfectly weighted and balanced so it feels just right in the hand.

Our Chef & Sommelier®, Arcoroc® and Sola® brands offer flatware designs from casual to elegant, calling on our European design heritage in thoroughly modern ways.

Choose among high luster, high quality stainless steel, satin, patina, oxidized, sand, colored PVD finishes—or request any pattern in either luxurious silverplate or a more contemporary brushed finish.



Made of the finest quality 18/10 heavy weight stainless steel, the Chef & Sommelier flatware collections are the final touch of elegance for a high end restaurant table.

The brand's range of cutlery is extremely resistant to corrosion, bending and twisting, and the wide range of designs allow it to meet the needs of different styles of establishments.



For over 150 years, this Swiss cutlery manufacturer offers high quality flatware combined with trendy designs.

Made in 18/10 stainless steel, Sola collections made of unique patterns and finishes to allow each style of high-end establishments to find the one that best suits them.



Offering numerous collections and solutions, Arcoroc flatware is enticing thanks to its good quality/price ratio.

The various designs, as well as the offerings in both 18/10 and 18/0, are the strong points of this brand's offer.

Crafted Excellence

Crafted from the highest quality 18/10 stainless steel which is an alloy of steel with chromium and/or added elements resistant to rust and corrosion.

Chromium / Nickel

1st Number 2nd Number

What is Stainless Steel?

Stainless steel is a durable and affordable metal that is used for a wide variety of purposes. It's strong, making it perfect for flatware and it's corrosion resistant, so it can last a long time without being replaced.

Chromium

Chromium is an essential element used in stainless steel for its durability and rust/stain resistant properties.

Nickel

Nickel is an element added to bring strength to the flatware as well as a soft luster similar to silver, producing a bright and polished look and also gives added resistance to corrosion.

18/10 Stainless Steel (304 Stainless)

Contains 18% chromium and 10% nickel. 18/10 is the highest quality stainless steel. This stainless is non-magnetic therefore it will not work in flatware retrievers.

18/8 Stainless Steel (304 Stainless)

Contains 18% chromium and 8% nickel. This stainless is non-magnetic therefore it will not work in flatware retrievers.

18/0 Stainless Steel (420 Stainless)

Contains 18% chromium and 0% nickel. 18/0 has an economic value which is usually seen at casual and high volume restaurants.

13/0 Stainless Steel (410 Stainless)

Contains 13% chromium and 0% nickel. This steel is used to make knives due to the softer properties.

Medium Weight

Medium weight flatware are patterns that are more economical and tend to be trendy and transitional. These patterns are ideal in casual, high-paced establishments as well as mid-level restaurants.

Heavy Weight

Heavy weight flatware are upscale patterns that can be found in high-end restaurants, upscale casual and fine dining and in hotels. They tend to be more modern in design.



NEW BLACK OAK SATIN 18/10

The sleek satin look of this bark like design brings a modern twist to the trendy natural aesthetic.

Available Q3

- FN995**
Dinner Fork 8 1/8" 3 Dz.
- FN996**
Dinner Knife (SH) 9 3/8" 3 Dz.
- FN997**
Dessert Spoon 7 3/8" 3 Dz.
- FN998**
Salad/Dessert Fork 7 1/2" 3 Dz.
- FP001**
US Teaspoon 6 1/8" 3 Dz.



DIAZ 18/10

Flared handles are classic yet contemporary.

- | | |
|--|--|
| <ul style="list-style-type: none"> T5101
Dinner Fork 8 1/4" 3 Dz. T5102
Dinner Spoon 8 1/4" 3 Dz. T5104
Dinner Knife (SH) 9 3/8" 3 Dz. T5105
Dessert Fork 7 1/4" 3 Dz. T5106
Dessert Spoon 7 1/4" 3 Dz. T5109
Soup Spoon 7" 3 Dz. T5110
Euro Teaspoon 5 1/2" 3 Dz. | <ul style="list-style-type: none"> T5111
Demitasse Spoon 4 1/2" 3 Dz. T5118
Iced Teaspoon 7 1/2" 3 Dz. T5121
Cocktail/Oyster Fork 5 7/8" 3 Dz. T5127
Butter Spreader 6 5/8" 3 Dz. T5128
US Teaspoon 6 1/8" 3 Dz. T5129
Salad Fork 7 1/4" 3 Dz. |
|--|--|





EZZO 18/10

Angled handles add a fresh hint of jazz.

- | | |
|--|---|
| T5201
Dinner Fork 8 1/4" 3 Dz. | T5211
Demitasse Spoon 4 1/2" 3 Dz. |
| T5202
Dinner Spoon 8 1/4" 3 Dz. | T5221
Cocktail/Oyster Fork 5 7/8" 3 Dz. |
| T5204
Dinner Knife (SH) 9 3/4" 3 Dz. | T5227
Butter Spreader 6 5/8" 3 Dz. |
| T5206
Dessert Spoon 7 1/4" 3 Dz. | T5228
US Teaspoon 6 1/8" 3 Dz. |
| T5209
Soup Spoon 7" 3 Dz. | T5229
Salad Fork 7 1/4" 3 Dz. |



FINN 18/10

Ultra-modern, European inspired design featuring slim handles and a dramatic knife blade.

- | |
|---|
| FL801
Dinner Fork 8" 3 Dz. |
| FL802
Dinner Spoon 8 1/8" 3 Dz. |
| FL804
Dinner Knife (SH) 9 1/4" 3 Dz. |
| FL806
Dessert Spoon 7 5/8" 3 Dz. |
| FL809
Soup Spoon 6 7/8" 3 Dz. |
| FL828
US Teaspoon 7" 3 Dz. |
| FL829
Salad/Dessert Fork 7 1/8" 3 Dz. |

FLUTED 18/10

Fluted handles separated by bands at the bottom and neck create a traditional poised look.

- FL201**
Dinner Fork 8 1/8" 3 Dz.
- FL202**
Dinner Spoon 8 5/8" 3 Dz.
- FL204**
Dinner Knife (SH) 8 7/8" 3 Dz.
- FL206**
Dessert Spoon 7 7/8" 3 Dz.
- FL209**
Soup Spoon 7" 3 Dz.
- FL211**
Demitasse Spoon 4 1/2" 3 Dz.

- FL218**
Iced Teaspoon 7" 3 Dz.
- FL221**
Cocktail/Oyster Fork 5 3/4" 3 Dz.
- FL227**
Butter Spreader 6 1/2" 3 Dz.
- FL228**
US Teaspoon 6 5/8" 3 Dz.
- FL229**
Salad Fork 7 1/8" 3 Dz.



HARPER 18/10

Squared and flared. Subtle impressions give handles a natural appeal.

- FL701**
Dinner Fork 8 1/8" 3 Dz.
- FL702**
Dinner Spoon 8 1/2" 3 Dz.
- FL704**
Dinner Knife (SH) 9 1/2" 3 Dz.
- FL706**
Dessert Spoon 7 1/2" 3 Dz.
- FL709**
Soup Spoon 7 1/8" 3 Dz.
- FL711**
Demitasse Spoon 4 3/4" 3 Dz.

- FL718**
Iced Teaspoon 7 1/4" 3 Dz.
- FL721**
Cocktail/Oyster Fork 6 5/8" 3 Dz.
- FL727**
Butter Spreader 6 3/8" 3 Dz.
- FL728**
US Teaspoon 6 3/4" 3 Dz.
- FL729**
Salad Fork 7 3/8" 3 Dz.





KNOX 18/10

Rounded heads with a hearty, hammered texture embellish the handles and discreetly hides fingerprints.

FK801

Dinner Fork 8 1/2" 3 Dz.

FK802

Dinner Spoon 8 5/8" 3 Dz.

FK804

Dinner Knife (SH) 9 1/2" 3 Dz.

FK806

Dessert Spoon 7 7/8" 3 Dz.

FK809

Soup Spoon 7 1/4" 3 Dz.

FK828

US Teaspoon 7 3/8" 3 Dz.

FK829

Salad/Dessert Fork 7 1/2" 3 Dz.

★
★
★
★
★
★
FLATWARE



KYA 18/10

Subtle curves create understated elegance.

T5401

Dinner Fork 8 1/8" 3 Dz.

T5402

Dinner Spoon 8 3/8" 3 Dz.

T5404

Dinner Knife (SH) 9 3/8" 3 Dz.

T5405

Dessert Fork 7 3/8" 3 Dz.

T5406

Dessert Spoon 7 3/8" 3 Dz.

T5408

Dessert Knife (SH) 8 1/4" 3 Dz.

T5409

Soup Spoon 7" 3 Dz.

T5410

Euro Teaspoon 5 1/2" 3 Dz.

T5411

Demitasse Spoon 4 1/2" 3 Dz.

T5427

Butter Spreader 6 5/8" 3 Dz.

T5428

US Teaspoon 6 1/8" 3 Dz.

T5429

Salad Fork 7 1/2" 3 Dz.

KYA SAND 18/10

A unique two-tone extension to our popular Kya collection featuring a mirror finish top and subtle sand handle for exceptional elegance and style.

FJ701

Dinner Fork 8 1/8" 3 Dz.

FJ704

Dinner Knife (SH) 9 3/8" 3 Dz.

FJ706

Dessert Spoon 7 3/8" 3 Dz.

FJ708

US Teaspoon 6 1/8" 3 Dz.

FJ709

Salad Fork 7 1/2" 3 Dz.

FG727

Butter Spreader 6 1/2" 3 Dz.



KYA BLACK 18/10

A bold take on our popular Kya collection, this explosive black PVD mirror finish offers a modern flair to all table settings.

FM301

Dinner Fork 8 1/8" 3 Dz.

FM304

Dinner Knife (SH) 9 3/8" 3 Dz.

FM306

Dessert Spoon 7 3/8" 3 Dz.

FM328

US Teaspoon 6 1/8" 3 Dz.

FM329

Salad Fork 7 1/2" 3 Dz.



★
 ★
 ★
 ★
 ★
 FLATWARE

NECTAR 18/10

Spatula shaped coffee and demitasse spoons for ladling cappuccino and latte froths.

T9010

Coffee Spoon 5 3/8" 1 Dz.

T9011

Demitasse Spoon 4 1/4" 1 Dz.



ORZON 18/10

Classic with reeded trim and curved details.

T4801

Dinner Fork 8 1/8" 3 Dz.

T4802

Dinner Spoon 8 1/8" 3 Dz.

T4804

Dinner Knife (SH) 9 5/8" 3 Dz.

T4806

Dessert Spoon 7 1/8" 3 Dz.

T4809

Soup Spoon 6 7/8" 3 Dz.

T4811

Demitasse Spoon 4 3/8" 3 Dz.

T4827

Butter Spreader 6 1/2" 3 Dz.

T4828

US Teaspoon 6" 3 Dz.

T4829

Salad Fork 7 1/4" 3 Dz.



RENZO PATINA 18/10

Vintage inspired, our Renzo Patina collection features a rumbled, antique distressed appearance from a tumbled process that brings traditional charm to the table. A soft, rich and warm finish brings this unique artisan collection to life.

FK501
 Dinner Fork 8 1/8" 3 Dz.

FK504
 Dinner Knife (SH) 9 5/8" 3 Dz.

FK506
 Dessert Spoon 7 1/4" 3 Dz.

FM711
 Demitasse Spoon 4 1/2" 3 Dz.

FM721
 Cocktail Fork 5 7/8" 3 Dz.

FK528
 US Teaspoon 6" 3 Dz.

FK529
 Salad/Dessert Fork 7 1/4" 3 Dz.



★
 ★
 ★
 ★
 ★
 ★
 FLATWARE

ALESSANDRIA 18/10

A classic beveled pattern with square handles are complementary to the trendy colors of today's table settings.

MB202

Table Knife (SH) 9 1/4" 1 dz.

MB201

Table Fork 8" 1 dz.

MB200

Tablespoon 8 1/8" 1 dz.

MB205

Dessert Knife 8 1/8" 1 dz.

MB204

Dessert/Fish Fork 7 3/8" 1 dz.

MB203

Dessert Spoon 7 3/8" 1 dz.

MB207

Soup Spoon 6 3/4" 1 dz.

MB220

American Teaspoon 6 1/8" 1 dz.

MB206

Teaspoon 5 3/4" 1 dz.

MB208

Coffee Spoon 4 1/2" 1 dz.

MB212

Fish Knife 7 3/4" 1 dz.

MB219

Butter Knife 7" 1 dz.



BAGUETTE BLACK 18/10

There's nothing traditional about this Baguette pattern. Black offers a bold statement for any table.

MB247

Table Knife (SH) 9" 1 dz.

MB246

Table Fork 8 1/8" 1 dz.

MB245

Tablespoon 8 1/8" 1 dz.

MB251

Dessert Knife 8" 1 dz.

MB250

Dessert Fork 7 3/8" 1 dz.

MB249

Dessert Spoon 7 3/8" 1 dz.

MB253

American Teaspoon 6" 1 dz.

MB248

Teaspoon 5 3/4" 1 dz.

MB252

Coffee Spoon 4 1/2" 1 dz.

MB254

Cake Fork 5 3/4" 1 dz.





BAGUETTE COPPER 18/10 NEW

There's nothing traditional about this Baguette pattern. Copper offers a trendy and unique presentation.

- | | |
|--|--|
| <p>FM571
Table Knife (SH) 9" 1 dz.</p> <p>FM575
Table Fork 8 1/8" 1 dz.</p> <p>FM577
Tablespoon 8 1/8" 1 dz.</p> <p>FM578
Dessert Knife 8" 1 dz.</p> <p>FM579
Dessert Fork 7 3/8" 1 dz.</p> | <p>FM580
Dessert Spoon 7 3/8" 1 dz.</p> <p>FM581
American Teaspoon 6" 1 dz.</p> <p>FM582
Teaspoon 5 3/4" 1 dz.</p> <p>FM583
Coffee Spoon 4 1/2" 1 dz.</p> <p>FM584
Cake Fork 5 3/4" 1 dz.</p> |
|--|--|



BAGUETTE GOLD 18/10

There's nothing traditional about this Baguette pattern. Gold offers a refined elegance.

- | | |
|--|--|
| <p>MB257
Table Knife (SH) 9" 1 dz.</p> <p>MB256
Table Fork 8 1/8" 1 dz.</p> <p>MB255
Tablespoon 8 1/8" 1 dz.</p> <p>MB261
Dessert Knife 8" 1 dz.</p> <p>MB260
Dessert Fork 7 3/8" 1 dz.</p> | <p>MB259
Dessert Spoon 7 3/8" 1 dz.</p> <p>MB263
American Teaspoon 6" 1 dz.</p> <p>MB258
Teaspoon 5 3/4" 1 dz.</p> <p>MB262
Coffee Spoon 4 1/2" 1 dz.</p> <p>MB264
Cake Fork 5 3/4" 1 dz.</p> |
|--|--|

NEW **BAGUETTE VINTAGE**
STONE WASH 18/10

There is nothing traditional about this Baguette pattern. Rustic is this pattern's middle name. Ideal for a hand crafted look and feel.

FL941
Table Knife (SH) 9" 1 dz.

FL942
Table Fork 8 1/8" 1 dz.

FL946
Tablespoon 8 1/8" 1 dz.

FL947
Dessert Knife 8" 1 dz.

FL948
Dessert Fork 7 3/8" 1 dz.

FL951
Dessert Spoon 7 3/8" 1 dz.

FL953
American Teaspoon 6" 1 dz.

FL952
Teaspoon 5 3/4" 1 dz.

FL886
Coffee Spoon 4 1/2" 1 dz.



CLOUD 18/10

Soft subtle curves elevate the look of sophisticated tablescapes for all types of establishments.

MB267
Table Knife (SH) 9 1/4" 1 dz.

MB266
Table Fork 8 1/8" 1 dz.

MB265
Tablespoon 8 1/8" 1 dz.

MB271
Dessert Knife (SH) 8 5/8" 1 dz.

MB270
Dessert Fork 7 3/8" 1 dz.

MB269
Dessert Spoon 7 3/8" 1 dz.

MB277
Soup Spoon 6 3/4" 1 dz.

MB275
American Teaspoon 6 1/4" 1 dz.

MB268
Teaspoon 5 3/4" 1 dz.

MB272
Coffee Spoon 4 1/2" 1 dz.

MB276
Steak Knife (SH) 9 1/4" 1 dz.

MB273
Cake Fork 6" 1 dz.

MB274
Iced Teaspoon 7 3/4" 1 dz.





EVE 18/10 **NEW**

This elegant mirror pattern is enhanced with the ergonomically designed beveled handle that fits perfectly in your hand.

SOE04
Table Knife (SH) 9 7/32" 1 dz.

SOE28
American Teaspoon 6 1/4" 1 dz.

SOE01
Table Fork 8 1/8" 1 dz.

SOE10
Teaspoon 5 11/16" 1 dz.

SOE02
Tablespoon 8 1/8" 1 dz.

SOE11
Coffee Spoon 4 11/16" 1 dz.

SOE08
Dessert Knife 8 1/4" 1 dz.

SOE20
Cake Fork 6 1/4" 1 dz.

SOE05
Dessert Fork 7 1/4" 1 dz.

SOE06
Dessert Spoon 7 1/4" 1 dz.

IMPERIAL CHOPSTICKS **NEW**

These sleek chop sticks are the perfect accompaniment for any Asian flair cuisine. The square handles make handling easy.

SCP99
Imperial Chop Sticks 8 3/4" 1 dz.

SCR98
Universal Chop Stick/ Knife Rest 2 3/4" 1 dz.



★ ★ ★ ★ ★ FLATWARE

LIVING MIRROR 18/10

Sleek contemporary handles make a dramatic statement for a variety of table settings.

MB298

Table Knife (SH) 9" 1 dz.

MB297

Table Fork 8 1/8" 1 dz.

MB296

Tablespoon 8 1/8" 1 dz.

MB301

Dessert Knife 8" 1 dz.

MB300

Dessert Fork 7 3/8" 1 dz.

MB299

Dessert Spoon 7 3/8" 1 dz.

MB312

Soup Spoon 7 1/8" 1 dz.

MB321

American Teaspoon 6 1/2" 1 dz.

MB302

Teaspoon 5 1/2" 1 dz.

MB303

Coffee Spoon 4 3/8" 1 dz.

MB311

Fish Knife 8 1/8" 1 dz.

MB314

Fish Fork 7 1/2" 1 dz.

LIVING MIRROR SPECIALTY ITEMS 18/10

Sleek specialty items that will complement any collection.

MB304

Cake Fork 6 1/2" 1 dz.

MB305

Iced Teaspoon 8 1/8" 1 dz.

MB315

Gourmet Spoon 7 5/8" 1 dz.

MB306

Salad Server Spoon 8 7/8" 1 dz.

MB307

Salad Server Fork 8 5/8" 1 dz.

MB308

Soup Ladle 10 7/8" (3 oz.) 1 dz.

MB309

Cake Server 10 1/8" 1 dz.

MB316

Large Iced Teaspoon 13 7/8" 1 dz.

MB317

Large Serving Spoon 15" 1 dz.

MB318

Large Slotted Spoon 15" 1 dz.

MB319

Large Serving Fork 5 1/8" 1 dz.

MB320

Large Spaghetti Spoon 14 3/4" 1 dz.





LIVING SATIN 18/10

Classic satin touch to the contemporary mirror adds flair to the modern shape.

- | | |
|--|--|
| MB324
Table Knife (SH) 9" 1 dz. | MB337
Soup Spoon 7 1/8" 1 dz. |
| MB323
Table Fork 8 1/8" 1 dz. | MB341
American Teaspoon 6 1/2" 1 dz. |
| MB322
Tablespoon 8 1/8" 1 dz. | MB325
Teaspoon 5 1/2" 1 dz. |
| MB328
Dessert Knife 8" 1 dz. | MB329
Coffee Spoon 4 3/8" 1 dz. |
| MB327
Dessert Fork 7 3/8" 1 dz. | MB331
Fish Knife 8 1/8" 1 dz. |
| MB326
Dessert Spoon 7 3/8" 1 dz. | MB339
Fish Fork 7 1/2" 1 dz. |

★ ★ ★ ★ ★
FLATWARE



NEW LUXUS SAND 18/10

The elegant sand touch at the bottom of the handle is a unique design on this stylish pattern.

- | | |
|--|--|
| SOL04
Table Knife (SH) 9 1/16" 1 dz. | SOL28
American Teaspoon 5 1/4" 1 dz. |
| SOL01
Table Fork 8 3/16" 1 dz. | SOL10
Teaspoon 5 1/2" 1 dz. |
| SOL02
Tablespoon 8 3/16" 1 dz. | SOL11
Coffee Spoon 4 5/16" 1 dz. |
| SOL08
Dessert Knife 8" 1 dz. | SOL20
Cake Fork 6 7/16" 1 dz. |
| SOL05
Dessert Fork 7 5/16" 1 dz. | SOL13
Fish Knife 8 1/8" 1 dz. |
| SOL06
Dessert Spoon 7 5/16" 1 dz. | |



MIRACLE 18/10

The Honeycomb design hides all imperfections but not the perfect style of this pattern.

SOM04

Table Knife (SH) 9 3/16" 1 dz.

SOM01

Table Fork 8 3/16" 1 dz.

SOM02

Tablespoon 8" 1 dz.

SOM08

Dessert Knife 8 3/16" 1 dz.

SOM05

Dessert Fork 7 1/4" 1 dz.

SOM06

Dessert Spoon 7 7/16" 1 dz.

SOM28

American Teaspoon 6 1/16" 1 dz.

SOM10

Teaspoon 5 13/16" 1 dz.

SOM11

Coffee Spoon 4 9/16" 1 dz.

SOM20

Cake Fork 5 15/16" 1 dz.

SOM13

Fish Knife 8 1/2" 1 dz.



3 PIECE TO GO FLATWARE



FN405

3 Piece To Go Flatware
 L: 7 15/16" W: 4 5/8" H: 8 13/16"
 Dinner Fork: 6 3/4"
 Dinner Knife: 6 3/4"
 Dinner Spoon: 6 13/16"
 3 dz.



Case Included



SUSTAINABLE - REPLACE DISPOSABLE CUTLERY

To Go cutlery is made of durable stainless steel and packed in a reusable case made with a mixture of wheat fiber. No longer do you need disposable cutlery!

★★★★★
 FLATWARE



UNIVERSAL SERVING ACCESSORIES 18/10

Essential serving pieces feature Vesca's simple straightforward design.

T1816

Serving Fork 10 1/8" 1 Dz.

T1817

Serving Spoon 10 1/8" 1 Dz.

T1826

Steak Knife (SH) 9 3/8" 1 Dz.

T1823

Cake Server 10" 1 Dz.

T1824

Sauce Ladle 6 7/8" (1 Oz.) 6 Pcs.

T1825

Soup Ladle 10 7/8" (5 Oz.) 6 Pcs.

T1822

Sauce Spoon 7 1/8" 1 Dz.

T1820

Cake Fork 5 7/8" 1 Dz.

T1819

Escargot Fork 5 7/8" 1 Dz.

T1821

Oyster/Cocktail Fork 5 5/8" 1 Dz.

T1818

Iced Teaspoon 7" 1 Dz.

T1812

Fish Fork 7 1/8" 1 Dz.

T1813

Fish Knife 7 7/8" 1 Dz.

★ ★ ★ ★ FLATWARE



BURLINGTON 18/10

NEW

Sophisticated, trendy, versatile Burlington creates a striking presentation for any table-scape.

EQ293

Table Knife (SH) 9 1/4" 1 dz.

EQ290

Table Fork 8 1/4" 1 dz.

EQ289

Table/Serving Spoon 8 1/8" 1 dz.

EQ291

Salad/Dessert Fork 7" 1 dz.

EQ284

Dessert/Oval Bowl Soup Spoon 6 13/16" 1 dz.

EQ285

Round Bowl Soup Spoon 6 3/8" 1 dz.

EQ283

American Teaspoon 6" 1 dz.

EQ287

Coffee Spoon 5 3/8" 1 dz.

EQ286

Iced Teaspoon 8" 1 dz.

EQ292

Cocktail Fork 6" 1 dz.

EQ294

Butter Knife 6 3/4" 1 dz.

EQ295

Steak Knife (SH) 9" 1 dz.

EQ288

Amuse/Tasting Spoon 5 1/4" 1 dz.

Amuse/Tasting Spoon

EMPIRE 18/10

Contemporary with a twist. Forks and spoons feature slightly rolled ends.

- T3501**
Dinner Fork 8 1/4" 1 Dz.
- T3502**
Dinner Spoon 8 1/4" 1 Dz.
- T3504**
Dinner Knife (SH) 9 3/8" 1 Dz.
- T3505**
Dessert Fork 7 1/4" 1 Dz.
- T3506**
Dessert Spoon 7 1/4" 1 Dz.
- T3528**
US Teaspoon 6" 1 Dz.
- T3529**
Salad Fork 7" 1 Dz.



LATHAM 18/10

These arcs get high marks for comfort and style.

- | | |
|---|---|
| <ul style="list-style-type: none"> T3601
Dinner Fork 8 1/4" 1 Dz. T3602
Dinner Spoon 8 1/4" 1 Dz. T3604
Dinner Knife (SH) 9 1/4" 1 Dz. T3605
Dessert Fork 7" 1 Dz. T3606
Dessert Spoon 7" 1 Dz. T3608
Dessert Knife (SH) 8 1/8" 1 Dz. | <ul style="list-style-type: none"> T3609
Soup Spoon 6 7/8" 1 Dz. T3611
Demitasse Spoon 4 3/8" 1 Dz. T3621
Oyster/Cocktail Fork 6" 1 Dz. T3627
Butter Spreader 7" 1 Dz. T3628
US Teaspoon 6" 1 Dz. T3629
Salad Fork 7" 1 Dz. |
|---|---|





LATHAM SAND 18/10

These arcs get high marks for comfort and style with a two tone finish.

FJ801

Dinner Fork 8 ¼" 1 Dz.

FJ804

Dinner Knife (SH) 9 ¼" 1 Dz.

FJ806

Dessert Spoon 7" 1 Dz.

FJ909

Butter Spreader 7" 1 Dz.

FJ911

Demitasse Spoon 4 ¾" 1 Dz.

FJ828

US Teaspoon 6" 1 Dz.

FJ829

Salad Fork 7" 1 Dz.

ON DEMAND contact Cardinal Sales (cardinalsales@arc-intl.com)

★
★
★
★
FLATWARE



MATIZ 18/10

Rounded ends bring dining full circle.

T1901

Dinner Fork 8" 1 Dz.

T1902

Dinner Spoon 8" 1 Dz.

T1904

Dinner Knife (SH) 9 ¼" 1 Dz.

T1906

Dessert Spoon 7 ½" 1 Dz.

T1909

Soup Spoon 6 ¾" 1 Dz.

T1911

Demitasse Spoon 4 ¾" 1 Dz.

T1928

US Teaspoon 6" 1 Dz.

T1929

Salad Fork 7" 1 Dz.

STONE 18/10

The hammered texture, medium weight and feel is the perfect complement to dress up your tabletop.

- T8001**
Dinner Fork 8" 1 Dz.
- T8002**
Dinner Spoon 8 1/8" 1 Dz.
- T8004**
Dinner Knife (SH) 9 1/2" 1 Dz.
- T8006**
Dessert Spoon 7" 1 Dz.
- T8008**
Dessert Knife (SH) 8 7/8" 1 Dz.

- T8009**
Soup Spoon 6 7/8" 1 Dz.
- T8011**
Demitasse Spoon 4 3/8" 1 Dz.
- T8018**
Iced Teaspoon 7 3/4" 1 Dz.
- T8028**
US Teaspoon 6" 1 Dz.
- T8029**
Salad Fork 6 7/8" 1 Dz.



STONE SATIN 18/10

Our Stone 18/10 flatware, with a satin finish. Ideal choice for everyday use with lustrous designs.

- FM601**
Dinner Fork 8" 1 Dz.
- FM604**
Dinner Knife (SH) 9 1/2" 1 Dz.
- FM606**
Dessert Spoon 7" 1 Dz.
- FM609**
Soup Spoon 6 7/8" 1 Dz.

- FM611**
Demitasse Spoon 4 3/8" 1 Dz.
- FM627**
Butter Spreader 6" 1 Dz.
- FM628**
US Teaspoon 6" 1 Dz.
- FM629**
Salad Fork 6 7/8" 1 Dz.



VESCA 18/10

Simple and straightforward has never seemed so fresh.



T1801
Dinner Fork 8" 1 Dz.

T1802
Dinner Spoon 8" 1 Dz.

T1804
Dinner Knife (SH) 9 1/4" 1 Dz.

T1805
Dessert Fork 7 1/8" 1 Dz.

T1806
Dessert Spoon 7 1/8" 1 Dz.

T1808
Dessert Knife (SH) 8 1/8" 1 Dz.

T1809
Soup Spoon 6 7/8" 1 Dz.

T1811
Demitasse Spoon 4 3/8" 1 Dz.

T1828
US Teaspoon 6" 1 Dz.

T1829
Salad Fork 7" 1 Dz.

AMBER 18/0

Sleek outlines surround sanded teardrop handles to create a chic, versatile look that hides fingerprints.



FL601
Dinner Fork 7 7/8" 1 Dz.

FL602
Dinner Spoon 8 1/4" 1 Dz.

FL604
Dinner Knife (SH) 9" 1 Dz.

FL606
Dessert Spoon 7 3/4" 1 Dz.

FL609
Soup Spoon 7 1/8" 1 Dz.

FL618
Iced Teaspoon 7 1/4" 1 Dz.

FL621
Oyster/Cocktail Fork 6 5/8" 1 Dz.

FL627
Butter Spreader 6 1/2" 1 Dz.

FL628
US Teaspoon 6 3/4" 1 Dz.

FL629
Salad/Dessert Fork 7 1/8" 1 Dz.

CAPITALE 18/0

Basic, essential and complete. The most common shapes and sizes at a value price point.

FG701

Dinner Fork 8 ¼" 3 Dz.

FG704

Dinner Knife (SH) 9 ¾" 3 Dz.

FG706

Dessert Spoon 7 ½" 3 Dz.

FG709

Soup Spoon 6 ¼" 3 Dz.

FG718

Iced Teaspoon 7 ½" 3 Dz.

FG726

Steak Knife (SH) 9 ¼" 1 Dz.

FG728

US Teaspoon 6 ⅞" 3 Dz.

FG729

Salad/Dessert Fork 7 ½" 3 Dz.



GREENWICH 18/0

Sleek softly curved heads with squared ends and narrow handles in a polished, modernly casual design.

FL501

Dinner Fork 7 ⅞" 1 Dz.

FL502

Dinner Spoon 8" 1 Dz.

FL504

Dinner Knife (SH) 9" 1 Dz.

FL506

Dessert Spoon 7 ½" 1 Dz.

FL509

Soup Spoon 6 ½" 1 Dz.

FL518

Iced Teaspoon 7 ¼" 1 Dz.

FL528

US Teaspoon 6 ¾" 1 Dz.

FL529

Salad/Dessert Fork 6 ⅞" 1 Dz.





HARRISON 18/0 NEW

Simple yet classic rim pattern is ideal for any casual environment. Coordinates with a multitude of decors and withstands the rigors of fast paced establishments.

- | | |
|---|---|
| <p>FM501
Dinner Fork 7 7/8" 1 Dz.</p> <p>FM502
Dinner Spoon 8 3/8" 1 Dz.</p> <p>FM504
Dinner Knife 9 1/8" 1 Dz.</p> <p>FM506
Dessert Spoon 7 1/8" 1 Dz.</p> <p>FM509
Soup Spoon 6 7/8" 1 Dz.</p> | <p>FM529
Salad/Dessert Fork 6 3/8" 1 Dz.</p> <p>FM505
US Salad Fork 7 3/16" 1 Dz.</p> <p>FM528
US Teaspoon 6 1/8" 1 Dz.</p> <p>FM518
Iced Teaspoon 7 1/2" 1 Dz.</p> <p>FM530
Euro Dinner Fork 8 3/8" 1 Dz.</p> |
|---|---|

LIV 18/0

A sharp square, straight line tapered handle in a classic design.



- | | |
|--|---|
| <p>FL401
Dinner Fork 8" 1 Dz.</p> <p>FL402
Dinner Spoon 8" 1 Dz.</p> <p>FL404
Dinner Knife (SH) 9 1/2" 1 Dz.</p> <p>FL406
Dessert Spoon 7 7/8" 1 Dz.</p> | <p>FL409
Soup Spoon 7" 1 Dz.</p> <p>FL418
Iced Teaspoon 6 7/8" 1 Dz.</p> <p>FL428
US Teaspoon 6 1/2" 1 Dz.</p> <p>FL429
Salad/Dessert Fork 6 7/8" 1 Dz.</p> |
|--|---|

MIKAYLA 18/0

Contemporary pieces of art that have bold yet discreet etched handles that mask fingerprint smudges.

FL101

Dinner Fork 8 ¼" 1 Dz.

FL102

Dinner Spoon 8 ¼" 1 Dz.

FL104

Dinner Knife (SH) 9" 1 Dz.

FL106

Dessert Spoon 7 ¾" 1 Dz.

FL109

Soup Spoon 6 ¾" 1 Dz.

FL118

Iced Teaspoon 7" 1 Dz.

FL121

Cocktail/Oyster Fork 5 ⅝" 1 Dz.

FL128

US Teaspoon 6 ⅞" 1 Dz.

FL129

Salad/Dessert Fork 7 ⅞" 1 Dz.



SATINEO 18/0

Smooth lines in a subtle satin finish.

T7801

Dinner Fork 8 ¼" 4 Dz.

T7802

Dinner Spoon 8 ¼" 4 Dz.

T7804

Dinner Knife (SH) 9 ⅜" 4 Dz.

T7805

Dessert Fork 7 ¼" 4 Dz.

T7806

Dessert Spoon 7 ¼" 4 Dz.

T7808

Dessert Knife (SH) 8 ¼" 4 Dz.

T7810

Euro Teaspoon 5 ½" 4 Dz.

T7811

Demitasse Spoon 4 ½" 4 Dz.

T7828

US Teaspoon 5 ⅞" 4 Dz.

T7829

Salad Fork 7 ⅞" 4 Dz.



STEAK KNIVES



FJ611 ●
 Regal Steak Knife (Rounded Tip) 9 3/8" 1 Dz.



FJ612 ●
 Regal Steak Knife (Pointed Tip) 9 3/8" 1 Dz.



FK603 ●
 Regal Steak Knife - Grey (Pointed Tip) 9 3/8" 1 Dz.



FM006 ●
 Marble Steak Knife, Serrated 9 1/4" 1 Dz.



FK307 ●
 Ellitte Steak Knife (Rounded Tip) 10 7/8" 1 Dz.



FN727 ●
 Marble Steak Knife, Non-Serrated 9 1/4" 1 Dz.

NEW



ESK01 ●
 Chelsea Steak Knife 10" 6 Pcs.



FJ605 ●
 Grand Steak Knife (Rounded Tip) 9 7/8" 1 Dz.



FJ517 ●
 Imperial Steak Knife (Solid Red) 9 5/8" 1 Dz.



FK491
 Steak Knife Box (Holds 6 Knives)
 (fits FJ506, FJ507, FJ508, FJ509, FJ516,
 FJ517, FM006, FJ611, FJ612, FK603)
 10 3/8" x 5 5/16" x 1 3/4"
 1 Dz.
 Knives not included



FJ516 ●
 Imperial Steak Knife (Solid Black) 9 5/8" 1 Dz.



FJ509 ●
 Imperial Steak Knife (Solid Grey) 9 5/8" 1 Dz.

★
 ★
 ★
 ★
 ★
 ★
 FLATWARE

H A N D L E M A T E R I A L

● POM

● Pakkawood

● Acrylic

STEAK KNIVES



FJ507 ●
 Imperial Steak Knife (Brown/Black) 9 5/8" 1 Dz.



FJ506 ●
 Imperial Steak Knife (Grey) 9 5/8" 1 Dz.



FJ508 ●
 Royale Steak Knife (Cherry) 9" 1 Dz.



FM026
 Black Oak Steak Knife 9 1/2" 3 Dz.



MB276
 Cloud Steak Knife (SH) 9 1/4" 1 dz.



T0426
 Universal (Lazzo) Steak Knife (SH) 9 1/2" 3 Dz.

STEAK KNIVES



ELG01 ●
 Beverly Steak Knife 9" 6 pcs.



EQ295
 Burlington Steak Knife (SH) 9" 1 Dz.



FG726
 Capitale Steak Knife (HH) 9" 6 pcs.



T1826
 Vesca Steak Knife (SH) 9 3/8" 1 Dz.

H A N D L E M A T E R I A L

● Pakkawood

● POM

★
 ★
 ★
 ★
 ★
 ★
 F L A T W A R E

Here at Arc Cardinal, we continue to evolve our product portfolio to meet the needs of today's customers. We are proud to announce we have taken steps beyond the table as we see opportunities to extend our product offering and partner with experienced brands in these markets.

BUFFETWARE



With over 40 years of experience in the industrial production of buffet items, the Abert brand offers top quality Italian craftsmanship and innovative designs. In perfect harmony with our other product ranges for the catering and hotel industries, the Abert collections allow you to create a unique buffet.

The thoughtful designs make it possible to personalize the buffet according to the menu and the style of the establishment thanks to the infinite possibilities between the tiles and the different materials within the Abert buffetware portfolio. The high quality of materials and functional designs will support the daily use of professionals: easy to clean and store while resistant to daily wear and tear.

INSULATED CARAFES



THERMOS. TRUSTED SINCE 1904.

Thermos® products deliver what matters every time. As the leading manufacturer of convenient insulated products for over 116 years, Thermos® brand is trusted by consumers to provide innovative portable containers that are high-performing and durable. Thermos® brand delivers when it matters. All backed with NSF Certification and Warranty. Arcoroc hot drink tableware perfectly complements the Thermos® brand.



FRESH. HOT. COLD.

alfi® brand products have set standards for the industry with its strict quality standards and award winning designs. alfi® is a German brand founded in 1914 and has been dedicated to making premium carafes for over 100 years. Add a perfect blend of function and elegance to any room. alfi® complements our high end dinnerware brands C&S and Dudson for a more refined option.

COOKWARE • SERVE WARE



PROUDLY HANDCRAFTED IN THE FRENCH ARDENNES

Chasseur's history is rooted in the very heart of the Champagne Ardennes region of France, known around the world for its food and wine. CHASSEUR® ("hunter" in French) is known as the Hunter of flavors, gourmet ideas, colors, and trends and is favored by top chefs from around the world.

Manufactured in the Invicta foundry and enameling plants, established in 1924, every product is backed with the "Guaranteed Made in France" promise. Chasseur® controls 100% of the manufacturing process in-house: design department, foundry and surface treatment.



COMPATIBLE WITH ALL HEAT SOURCES

 INDUCTION	 GAS	 SOLID HOB	 RADIANT GLASS CERAMIC	 HALOGEN	 OVEN
--	--	--	--	--	---

CHEF KNIVES • CUTLERY



Richardson
Sheffield
Since 1839

A BRITISH BRAND SINCE 1839 • EXPERIENCED KNIFE PRODUCER

Richardson Sheffield's rich heritage gives them an unparalleled expertise and unrivaled specialist knowledge, as well as a name that's synonymous with uncompromising quality, smart design and technological innovation.



Their designs range from accessible starter products suited for the beginner to superb enthusiast ranges. Perfect for budding chefs of all kinds, offering premium knife collections for professional chefs with superior quality and value at every level.

Each knife is exceptionally hand finished using only the finest materials for lasting performance and durability. They are manufactured to extremely high-quality standards. Every production run is carefully checked by their qualified inspectors to ensure that it has been made to Richardson Sheffield's demanding quality levels.

SMALLWARES



Manufactured from powder coated steel which protects from rust and scratches, podiums add different height elevations to the buffet. Available in 3 colors, black, white and copper

NEW

DOMINO | STEEL

abert
BUFFETWARE



Domino Podium FP034 White
L: 15 3/4" W: 7 7/8" H: 3 1/2" FP032 Black
1 Pc. FP033 Copper
Fits 2 Tiles



Domino Podium FP037 White
L: 15 3/4" W: 7 7/8" H: 7 7/8" FP035 Black
1 Pc. FP036 Copper
Fits 2 Tiles



Domino Podium FP040 White
L: 23 5/8" W: 7 7/8" H: 3 1/2" FP038 Black
1 Pc. FP039 Copper
Fits 3 Tiles



Domino Podium FP043 White
L: 23 5/8" W: 7 7/8" H: 7 7/8" FP041 Black
1 Pc. FP042 Copper
Fits 3 Tiles



Domino Podium FP046 White
L: 15 3/4" W: 15 3/4" H: 3 1/2" FP044 Black
1 Pc. FP045 Copper
Fits 4 Tiles



Domino Podium FP049 White
L: 23 5/8" W: 15 3/4" H: 3 1/2" FP047 Black
1 Pc. FP048 Copper
Fits 6 Tiles

Perfectly Matches The Domino Wood Frames
Smooth Finish Ensures The Stands Will Not Scratch Any Surfaces
Two Different Height Options For Each Size Are Offered For Adding Elevation
Fits Tile Options On Page 261

★
★
★
★
DISPLAY • RISERS



Domino frames are made in Ash wood, known for being a dense and durable wood featuring meandering grain patterns. Each frame is stackable which is perfect for doubling up to add elevation on the buffet and for easy storage.

NEW

DOMINO

SOLID WOOD

abert
BUFFETWARE

Domino Frame FP021 White
L: 15 3/4" W: 7 7/8" H: 2" **FP022** Black
1 Pc.

Fits 2 Tiles or the 3- Pitcher Stand



Domino Frame FP023 White
L: 23 5/8" W: 7 7/8" H: 2" **FP024** Black
1 Pc.

Fits 3 Tiles Alone,
Ice Pack Holder & Cover Alone,
Or A Tile And 3 Pitcher Stand



Domino Frame FP025 White
L: 15 3/4" W: 15 3/4" H: 2" **FP026** Black
1 Pc.

Fits 4 Tiles Alone
Or A Combo Of Tiles &
The 3 Pitcher Stand



Domino Frame FP027 White
L: 23 5/8" W: 15 3/4" H: 2" **FP028** Black
1 Pc.

Fits 6 Tiles Alone,
A Combo Of Tiles,
Ice Pack Holder & Cover,
Or The 3 Pitcher Stand



Stackable - perfect for doubling up to add elevation on the buffet and for easy storage
See Tile & Steel Accessories On Page 12 & 13

★
★
★
★
DISPLAY • RISERS



Tiles from Domino collection are made in vitrified porcelain; a material strong, resistant to wear and tear, light and water, oil and grease proof.
Mix the various pattern tiles with Domino frames and Domino podiums to create a unique buffet.

DISPLAY • RISERS



Domino Rectangular Ice Pack FP063
1 Pc.



3-Pitcher Stand FP061
L: 15 3/4" W: 7 7/8"
1 Pc.
Fits Domino Wood Frames



Ice-Pack / Crumb Holder FP060
L: 23 5/8" W: 6 1/4"
1 Pc.
Fits The Domino Frame
FP023, FP024, FP027 or FP028



Ice-Pack Cover Per Thermal Set FP058
L: 22" W: 6 1/4"
1 Pc.

NEW

DOMINO

PORCELAIN

abert
BUFFETWARE

Domino Gray Mix Tile FP012

L: 7 7/8" W: 7 7/8"
25 Pcs.

Other styles shown on ArcCardinal.com



Domino Blue Mix Tile FP017

L: 7 7/8" W: 7 7/8"
25 Pcs.

Other styles shown on ArcCardinal.com



Domino Copper Mix Tile FP016

L: 7 7/8" W: 7 7/8"
25 Pcs.

Other styles shown on ArcCardinal.com



Domino Tan Mix Tile FP020

L: 7 7/8" W: 7 7/8"
25 Pcs.

Other styles shown on ArcCardinal.com



Domino Dark Grey Tile FP019

L: 7 7/8" W: 7 7/8"
25 Pcs.



Domino Light Grey Tile FP018

L: 7 7/8" W: 7 7/8"
25 Pcs.



★
★
★
★
DISPLAY • RISERS



Unique by design and functionality, simple clean lines and effortless dispensing will complement any buffet



Juice Dispenser FP054
8 Liters
H: 22"
1 Pc.

Juice dispenser made in durable acrylic that offers an exceptional clarity and it can be use with or without the included Ice pack to keep drinks cold.



Coffee Urn FP055
10 Liters
H: 20 1/8"
1 Pc.

Heated by chafing fuel, the coffee urn made in stainless steel is easy to transport due to the two nobs on each side.



Individual Cereal Dispenser FP056
3 Liters
H: 20 7/8"
1 Pc.

This cereal dispenser has a rubber paddle which dispenses a controlled portion of cereal or snacks.



Jam/Honey Dispenser FP067
Base: 13 3/8" x 5"
Max Height: 22 7/8"
1 Pc.

The jam/honey dispenser can be use with the Jambee Nozzle (FP068- sold separately) to infuse jam or honey into a croissant or muffin and has a disk inside the tube that cleans the walls of the dispenser.



Jambee Nozzle 18/10 FP068
1 Pc.

Nozzle to be used with Jam & Honey Dispenser (FP067)



Drip Tray w/ Grill 18/10 FP062
L: 6 1/4" W: 6 1/4"
1 Pc.

Optional magnetic drip tray sold separately can be use for the coffee urn and the juice dispenser.

NEW

COSMO | IMPERFETTO

abert
BUFFETWARE



Centerpiece Wood 18/10 FP051
D: 12 ¼" H: 2 ¾"
1 Pc.



Centerpiece Wood 18/10 FP050
D: 14 ½" H: 1 ½"
1 Pc.



Centerpiece Wood 18/10 FP053
D: 16 ½" H: 2 ¾"
1 Pc.



Centerpiece Wood 18/10 FP052
D: 14 ½" H: 2 ¾"
1 Pc.

Platters that brings design to the buffet and allows a nice presentation of the food.

CHAFFING DISH



Chafing Dish GN 2/3 with Black Support FP057
L:16 ¼ W:16 H:10 ¼
1 Pc.

Modern style for this 2/3 size 18/10 chafing dish that will perfectly match with the rest of the collections.

Includes a durable black powder coated steel standard removable pan. Can be heated by chafing fuel or electric unit.

✓Soft Close Hinge ✓ An innovative evaporation system -the chafing dish has a thin slot in the lid allowing steam to exit.

★
★
★
★
DISPLAY • RISERS



Mix&Play ready-to-use sets are made from wood with a powder coated steel stand. The 3 different structures can be combined together to offer an even larger buffet set.



Mix&Play Revolution Set A FP064
L: 27 1/2" W: 20 5/8" H: 9 1/2"
1 Pc.



Mix&Play Revolution Set B FP065
L: 27 1/2" W: 20 5/8" H: 8 7/8"
1 Pc.



Mix&Play Revolution Set C FP066
L: 27 1/2" W: 20 5/8" H: 8 7/8"
1 Pc.

DISPLAY • RISERS

NEW



Buffet Stand FP029
L:11" W: 11" H: 7 7/8"
1 Pc.



Buffet Stand FP030
L:11" W: 11" H: 9 7/8"
1 Pc.



Buffet Stand FP031
L:11" W: 11" H: 11 3/4"
1 Pc.



Base, Round, Matte Black FP059
W: 7 1/4"
1 Pc.

Arc Cardinal Items That Fit
FH289 (Candour)
R0947 (Vintage)
N9362 (Evolutions)
N2420 (Louison)



★
★
★
★
DISPLAY • RISERS

On Stage stands are made in powder coated stainless steel Add elevation to the buffet and possibility to use the stand with or without the base and to replace it by a salad bowl.

alfi[®] ALBERGO

NEW



Classical motif and modern technology; utilitarian and decorative design that demonstrates how seemingly contrasting elements can interact perfectly together.

ALFI is a registered trademark owned by Alfi GmbH IsoliergefäÙe, Metall- und Haushaltswaren in the U.S. and other countries.

NEW

ALBERGO



FN345/ AS2710SS2*
Albergo Top Therm 1.5 Liter (50 oz.)
L: 5 7/8" W: 7 8/25" H: 9 1/2"
2 Pc.



FN347/ AS2700SS2*
Albergo Top Therm 1 Liter (34 oz.)
L: 5 4/25" W: 6 4/5" H: 8 7/10"
2 Pc.



24 HOURS COLD



12 HOURS HOT

SPOUT SYSTEM
CHROME PLATED PLASTIC

DURABLE STAINLESS STEEL
INTERIOR AND EXTERIOR



TOP THERM VACUUM STAINLESS STEEL BODY

INSULATED CARAFES ★★★★★

* alfi SKU, Use for Reference ONLY

ALFI is a registered trademark owned by Alfi GmbH IsoliergefäÙe, Metall- und Haushaltswaren in the U.S. and other countries.



GUSTO TOP THERM

NEW



Gusto TT has an ultra-modern body that is seamlessly integrated within its ultra classic design. With its aesthetics and ergonomics in product design, Gusto has a new comfortable pouring system for easy pouring. Brush finish adds a touch of elegance and prevents finger-print markings.

ALFI is a registered trademark owned by Alfi GmbH Isoliergefäße, Metall- und Haushaltswaren in the U.S. and other countries.

NEW

GUSTO TOP THERM



FN353/ AS2000SS2*

Gusto Top Therm 0.6 Liter (20 oz.)
L: 6 1/2" W: 4 1/2" H: 7 1/25"
2 Pc.



FN352/ AS2010SS2*

Gusto Top Therm 1 Liter (34 oz.)
L: 4 9/10" W: 6 1/2" H: 8 19/20"
2 Pc.



FN351/ AS2020SS2*

Gusto Top Therm 1.5 Liter (50 oz.)
L: 5 7/20" W: 6 3/5" H: 10 3/5"
2 Pc.



FN354/ AS2020SS2COF*

Gusto Top Therm-Imprinted "COFFEE" 1.5
Liter (50 oz.)
L: 5 7/20" W: 6 3/5" H: 10 3/5"
2 Pc.



FN355/ AS2020SS2DEC*

Gusto Top Therm-Imprinted "DECAF" 1.5 Liter
(50 oz.)
L: 5 7/20" W: 6 3/5" H: 10 3/5"
2 Pc.



FN356/ AS2020SS2HW*

Gusto Top Therm-Imprinted "HOT WATER" 1.5
Liter (50 oz.)
L: 5 7/20" W: 6 3/5" H: 10 3/5"
2 Pc.



DISHWASHER SAFE



24 HOURS COLD



12 HOURS HOT

SPOUT SYSTEM
CHROME PLATED METAL

DURABLE STAINLESS STEEL
INTERIOR AND EXTERIOR



TOP THERM VACUUM STAINLESS STEEL BODY

* alfi SKU, Use for Reference ONLY

ALFI is a registered trademark owned by Alfi GmbH IsoliergefäÙe, Metall- und Haushaltswaren in the U.S. and other countries.

INSULATED CARAFES



HOTELLO

NEW



The first of its kind to be designed specifically for the Hospitality industry.
The Hotello was designed with a completely unique sealing system that has no plastic or silicone parts.

ALFI is a registered trademark owned by Alfi GmbH IsoliergefäÙe, Metall- und Haushaltswaren in the U.S. and other countries.

NEW

HOTELLO



FN349/ AS2630SS2*
Hotello 1.5 Liter (50 oz.)
L: 4 9/16" W: 5 1/8" H: 10 1/2"
2 Pc.



FN348/ AS2620SS2*
Hotello 1 Liter (34 oz.)
L: 4 9/16" W: 5 1/8" H: 8 3/8"
2 Pc.

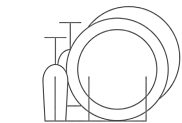

DISHWASHER SAFE



16 HOURS COLD



8 HOURS HOT

TOP THERM VACUUM
STAINLESS STEEL BODY

DURABLE STAINLESS STEEL
INTERIOR AND EXTERIOR



SPECIALLY DEVELOPED
HINGED LID WITH ONE
HAND OPERATION

INSULATED CARAFES ★★★★★

* alfi SKU, Use for Reference ONLY

alfi® LIGHTWEIGHT CARAFE **NEW**



Premium vacuum carafe in a sleek frosted black design adds elegance to beverage service.

ALFI is a registered trademark owned by Alfi GmbH Isoliergefäße, Metall- und Haushaltswaren in the U.S. and other countries.

NEW

LIGHTWEIGHT CARAFE



ALFIDUR VACUUM
HARD GLASS LINER



COMFORTABLE SPOUT
SYSTEM WITH ONE
HAND OPERATION

HIGH QUALITY PLASTIC WITH
FROSTED SURFACE

FN350/ AG2800BK2*

Plastic Black Frosted Surface, Vacuum Glass Insert 1 Liter (34 oz)

L: 5 3/8" W: 6 1/2" H: 10 1/25"

2 Pc.

TECHNOLOGY

5 Layers For Improved Insulation

Alfi 5 layer insulation technology that has silvering on both sides of its space between the glass layers and is equipped with a lasting vacuum. Therefore the carafe maintains the beverage temperature for longer.



24 HOURS COLD



12 HOURS HOT

*** alfi SKU, Use for Reference ONLY**

INSULATED CARAFES ★★★★★



BREW IN CARAFE

NEW



Thermos Professional Brew In Carafe with vacuum insulation technology for maximum temperature retention.

THERMOS is a registered trademark in over 115 countries.

NEW

BREW IN CARAFE



FN371/TGU1900SC6*

NSF Cert. S.S. Brew In Vac. Carafe

1.9 L (64 oz)

L: 5" W: 5 31/50" H: 11 3/25"

6 Pc.

Replacement Accessories



FN444/ RTGUDC25*

Brew-In Decaf Lid for
FN371, FN372, FN370, FN357, FN369
6 Pc.



FN445/ RTGUG25*

Brew-In Tea Lid for
FN371, FN372, FN370, FN357, FN369
6 Pc.



FN446/ RTGUL25*

Brew-In Coffee/ Hot Water Lid for
FN371, FN372, FN370, FN357, FN369
6 Pc.



6 HOURS HOT
173.5 °F (78.6 °C)



6 HOURS COLD
37.4 °F (3 °C)



* Thermos SKU, Use for Reference ONLY

THERMOS is a registered trademark in over 115 countries.



INSULATED CARAFES



CARAFE W/ GAUGE

NEW

★
★
★
★
INSULATED
CARAFES



DIRECT BREW-IN FRESH ZONE STOPPER; FITS UNDER MOST BREWERS



EXTERIOR STAYS COOL TO THE TOUCH WITH HOT CONTENTS AND SWEAT-PROOF WITH COLD

ERGONOMICALLY DESIGNED "OPEN HANDLE" FOR MANY POURING POSITIONS

THERMOS™ VACUUM INSULATION TECHNOLOGY FOR MAXIMUM TEMPERATURE RETENTION

DURABLE TYPE 304 STAINLESS STEEL INTERIOR AND EXTERIOR

LIGHTWEIGHT AND EASY TO CARRY

NSF CERTIFIED MEETS STRICT NSF FOOD AND PRODUCT SAFETY STANDARDS



DISHWASHER SAFE



Brewer carafe with fresh zone stopper and gauge fits under most brewers. Thermos vacuum insulation technology for maximum temperature retention.



FN372/ THF19SCLG4MD*
 NSF Cert. S.S. Vac. Carafe w/Gauge
 1.9 L (64 oz)
 L: 7" W: 8 1/2" H: 7 4/5"
 4 Pc.

INSULATED CARAFES ★★★★★

Replacement Accessories



FN373/ THF0208*
 Fresh Zone Stopper w/ Gauge
 w/ Care and Use and Brush for FN372
 10 Pc.



FN441/ RTGSDC25*
 Push Button Decaf Lid for
 FN370, FN357, FN369, FN372
 6 Pc.



FN442/ RTGSG25*
 Push Button Tea Lid for
 FN370, FN357, FN369, FN372
 6 Pc.



FN443/ RTGSL25*
 Push Button Coffee/ Hot Water Lid for
 FN370, FN357, FN369, FN372
 6 Pc.



FN444/ RTGUDC25*
 Brew-In Decaf Lid for
 FN371, FN372, FN370, FN357, FN369
 6 Pc.



FN445/ RTGUG25*
 Brew-In Tea Lid for
 FN371, FN372, FN370, FN357, FN369
 6 Pc.



FN446/ RTGUL25*
 Brew-In Coffee/ Hot Water Lid for
 FN371, FN372, FN370, FN357, FN369
 6 Pc.

 **6 HOURS HOT**
 160.2°F (71.2°C)

 **6 HOURS COLD**
 38.7°F (3.7°C)



* Thermos SKU, Use for Reference ONLY

THERMOS is a registered trademark in over 115 countries.



CARAFE W/ LEVER **NEW**



DESIGNED FOR PROFESSIONAL EVERYDAY USE.

Features a lever-operated stopper and a double wall stainless steel body to help keep coffee or tea at the perfect temperature.

THERMOS is a registered trademark in over 115 countries.



6 HOURS HOT 178.2 °F (81.2 °C)
6 HOURS COLD 37.8 °F (3.2 °C)



FN370/ TGS15SC*
 NSF Cert. S.S. Push Button Vac. Carafe
 1.5 L (50 oz)
 L: 5" W: 6 3/8" H: 10"
 6 Pc.



6 HOURS HOT 169.3 °F (76.3 °C)
6 HOURS COLD 39.2 °F (4 °C)



FN357/ TGS10SC*
 NSF Cert. S.S. Push Button Vac. Carafe
 1 L (34 oz.)
 L: 5" W: 6 3/8" H: 7 9/16"
 6 Pc.



6 HOURS HOT 156.6 °F (69.2 °C)
6 HOURS COLD 41.5 °F (5.3 °C)



FN369/ TGS06SC*
 NSF Cert. S.S. Push Button Vac. Carafe
 0.6 L (20 oz)
 L: 5" W: 6 3/8" H: 6 1/2"
 6 Pc.

Replacement Accessories



FN441/ RTGSDC25*
 Push Button Decaf Lid for
 FN370, FN357, FN369, FN372
 6 Pc.



FN444/ RTGUDC25*
 Brew-In Decaf Lid for
 FN371, FN372, FN370, FN357, FN369
 6 Pc.



FN442/ RTGSG25*
 Push Button Tea Lid for
 FN370, FN357, FN369, FN372
 6 Pc.



FN445/ RTGUG25*
 Brew-In Tea Lid for
 FN371, FN372, FN370, FN357, FN369
 6 Pc.



FN443/ RTGSL25*
 Push Button Coffee/ Hot Water Lid for
 FN370, FN357, FN369, FN372
 6 Pc.



FN446/ RTGUL25*
 Brew-In Coffee/ Hot Water Lid for
 FN371, FN372, FN370, FN357, FN369
 6 Pc.



DURABLE TYPE 304
 STAINLESS STEEL
 INTERIOR AND
 EXTERIOR

FINGER PRINT RESISTANT CLEAR
 EXTERIOR FINISH



LEVER OPERATED
 ONE- PUSH STOPPER

THERMOS™ VACUUM
 INSULATION TECHNOLOGY FOR
 MAXIMUM TEMPERATURE
 RETENTION

* Thermos SKU, Use for Reference ONLY

THERMOS is a registered trademark in over 115 countries.

INSULATED CARAFES



TWIST AND POUR

NEW



LID HAS DOUBLE SILICONE GASKET TO MINIMIZE SPILLS AND ASSISTS IN TEMPERATURE RETENTION

THERMOS™ VACUUM INSULATION TECHNOLOGY FOR MAXIMUM TEMPERATURE RETENTION

DURABLE TYPE 304 STAINLESS STEEL INTERIOR AND EXTERIOR

Allows for cold storage of dairy products* and hot drinks by the coffee station. Sturdy ergonomic and lightweight designed handle for easy pouring. Double silicone gasket on lid minimizes spills and helps with temperature retention.

*See Care & Use for Details

THERMOS is a registered trademark in over 115 countries.



NEW

TWIST AND POUR



 6 HOURS HOT
173.5°F (78.6°C)

 6 HOURS COLD
38.8°F (3.8°C)

FN361/TGB06SC*
NSF Cert. S.S. Vac. Carafe Twist/Pour
0.6 L (20 oz)
L: 4" W: 5 1/2" H: 8 1/8"
6 Pc.



 6 HOURS HOT
178.2°F (81.2°C)

 6 HOURS COLD
37.6°F (3.1°C)

FN368/TGM10SC*
NSF Cert. S.S. Vac. Carafe Twist/Pour
1 L (34 oz)
L: 4 1/2" W: 6 3/8" H: 10 3/8"
6 Pc.



FN363/TGB10SCHH6*
NSF Cert. S.S. Vac. Carafe Twist/Pour
"HALF & HALF" Imprint
0.9 L (32 oz)
L: 4 1/2" W: 5 1/2" H: 11 3/8"
6 Pc.



FN364/TGB10SCCR6*
NSF Cert. S.S. Vac. Carafe Twist/Pour
"CREAM" Imprint
0.9 L (32 oz)
L: 4 1/2" W: 5 1/2" H: 11 3/8"
6 Pc.



FN365/TGB10SCLF6*
NSF Cert. S.S. Vac. Carafe Twist/Pour
"LOW FAT" Imprint
0.9 L (32 oz)
L: 4 1/2" W: 5 1/2" H: 11 3/8"
6 Pc.



FN366/TGB10SCML6*
NSF Cert. S.S. Vac. Carafe Twist/Pour
"MILK" Imprint
0.9 L (32 oz)
L: 4 1/2" W: 5 1/2" H: 11 3/8"
6 Pc.





FN367/TGB10SCSK6*
NSF Cert. S.S. Vac. Carafe Twist/Pour
"SKIM" Imprint
0.9 L (32 oz)
L: 4 1/2" W: 5 1/2" H: 11 3/8"
6 Pc.



FN362/TGB10SC*
NSF Cert. S.S. Vac. Carafe Twist/Pour
0.9 L (32 oz)
L: 4 1/2" W: 5 1/2" H: 11 3/8"
6 Pc.

32 OZ. CARAFES

 6 HOURS HOT
182.7°F (83.7°C)

 6 HOURS COLD
37.0°F (2.8°C)



*** Thermos SKU, Use for Reference ONLY**

THERMOS is a registered trademark in over 115 countries.

INSULATED CARAFES



ACCESSORIES FOR THERMOS® BRAND PRODUCTS

NEW



FN441/ RTGSDC25*
Push Button Decaf Lid for
FN370, FN357, FN369, FN372
6 Pc.



FN442/ RTGSG25*
Push Button Tea Lid for
FN370, FN357, FN369, FN372
6 Pc.



FN443/ RTGSL25*
Push Button Coffee/ Hot Water Lid for
FN370, FN357, FN369, FN372
6 Pc.



FN444/ RTGUDC25*
Brew-In Decaf Lid for
FN371, FN372, FN370, FN357, FN369
6 Pc.



FN445/ RTGUG25*
Brew-In Tea Lid for
FN371, FN372, FN370, FN357, FN369
6 Pc.



FN446/ RTGUL25*
Brew-In Coffee/ Hot Water Lid for
FN371, FN372, FN370, FN357, FN369
6 Pc.



FN447/ TGB900525*
Replacement TGB Stopper for:
FN361 FN366
FN363 FN367
FN364 FN362
FN365
6 Pc.



FN448/ TGM1005125*
Replacement Stopper for FN368
6 Pc.



FN373/ THF0208*
Fresh Zone Stopper w/ Gauge
w/ Care and Use and Brush for FN372
10 Pc.



INSULATED CARRAFES

* Thermos SKU, Use for Reference ONLY

THERMOS is a registered trademark in over 115 countries.



INSULATED CARAFES ★★ ★★ ★★ ★★

CHASSEUR

ROUND & OVAL CASSEROLE **NEW**



Cast iron is compatible with all heat sources including induction which makes the perfect presentation for any buffet. It makes a dramatic statement with its stylish look and trendy colors as well as retaining its heat while serving up favorite buffet items.

NEW

ROUND & OVAL CASSEROLE

CHASSEUR®



Mini Round Casserole FN421 Matte Black
FN422 Red
 0.37 Q (11 7/8 oz.)
 3 1/8" (10 cm)
 1 Pc.



Mini Round Casserole FN423 Matte Black
FN424 Red
 0.63 Q (20 1/4 oz.)
 4 3/4" (12 cm)
 1 Pc.



Round Casserole FN425 Matte Black
FN426 Red
FN949 Quartz
FN950 Grey
 4.23 Q (135 oz.)
 9 1/2" (24 cm)
 1 Pc.



Round Casserole FN427 Matte Black
FN428 Red
FN951 Quartz
FN952 Grey
 6.44 Q (206 oz.)
 11" (28 cm)
 1 Pc.



COOKWARE • SERVE WARE

CHASSEUR

ROUND & OVAL LOW CASSEROLE

NEW



The round and oval low casseroles are the ultimate multi-use pan. The stylish lidded casserole is perfect for creating one dish meals and the perfect vessels for sides such as risotto and roasted vegetables.

NEW

ROUND & OVAL LOW CASSEROLE

CHASSEUR®



FN437

Round Serving Matte Black Casserole 1.8 Q (57 ⅓ oz.)
9 ½" (24 cm)
1 Pc.



FN438

Round Serving Ruby Casserole 1.8 Q (57 ⅓ oz.)
9 ½" (24 cm)
1 Pc.



FN432

Oval Matte Black Casserole 4.23 Q (135 ¼ oz.)
10 ⅝" (27 cm)
1 Pc.



FN433

Oval Ruby Casserole 4.23 Q (135 ¼ oz.)
10 ⅝" (27 cm)
1 Pc.



FN431

Oval Matte Black Casserole 6.34 Q (202 ⅞ oz.)
12 ¼" (31 cm)
1 Pc.



COOKWARE • SERVEWARE

CHASSEUR

TERRINE • RECTANGLE • GRATIN

NEW



The rectangular and gratin dishes make perfect casseroles and lasagnas. This multi-use item can serve as trendy vessels to serve desserts in like creme bruleé. The two terrine sizes are not only essential for slowly cooking pâtés but make great pans for meatloafs and small casseroles.

NEW

TERRINE • RECTANGLE • GRATIN

CHASSEUR



FN429
Rectangular Matte Black Terrine
9 7/8" (25 cm)
1 Pc.



FN430
Rectangular Matte Black Terrine
10 1/2" (20 cm)
1 Pc.



FN435
Rectangular Matte Black Baking Dish
8 7/8" x 5 1/8" (22 1/2 cm)
1 Pc.



FN436
Gratin Matte Black Baking Dish
11 1/2" x 8" (29 cm)
1 Pc.



FN434
Gratin Matte Black Baking Dish
7 1/2" X 4 3/4 (18 1/2 cm)
1 Pc.



COOKWARE • SERVE WARE

Measurements Are The Inside Dimensions

CHASSEUR

ROUND & OVAL DISH

NEW



Enameled cast iron is perfect for sautéing, roasting and stewing – it warms gradually, heats evenly and retains heat for a long time.

NEW

ROUND & OVAL DISH

CHASSEUR®



FN417
Round Matte Black Dish
5 7/8" (15 cm)
1 Pc.



FN418
Round Matte Black Dish
7 1/6" (18 cm)
1 Pc.



FN419
Oval Matte Black Dish
7 7/8" x 5 7/8" (20 cm)
1 Pc.



FN420
Oval Matte Black Dish
11" x 7 7/8" (28 cm)
1 Pc.

NEW

TRIVETS

ARCOROC



FN976
Round Trivet
10"
6 Pc.



FN977
Oval Trivet
L: 11 1/2" W: 10"
6 Pc.



FN978
Oval Trivet
L: 13" W: 8 1/2"
6 Pc.



COOKWARE • SERVE WARE



Richardson
Sheffield
Since 1839

VULCANO NEW



The modern touch and style of the POM crafted handle along with the highest quality MOV steel is a must have for any professional chef. The rounded back of the blade offers optimum comfort during use. The full tang offers the best cutting experience possible while the stainless steel rivets assure a firm grip.



ROUND
BACK



EXTRA
SHARP



FN169 Paring Knife 3 1/2" 6 Pcs.



FN216 All Purpose Knife 9 1/4" 6 Pcs.



FN171 Boning Knife 5" 6 Pcs.

Max 140 degrees Fahrenheit;
Phosphate free; low salt



Measurements Are Blade Length

NEW

VULCANO



Richardson
Sheffield
Since 1839



FN175 Flexible Sole Knife 7" 6 Pcs.



FN176 Santoku 7" 6 Pcs.



FN177 Bread 8" 6 Pcs.



FN178 Chef Knife 6 1/2" 6 Pcs.



FN179 Chef Knife 8" 6 Pcs.



FN180 Chef Knife 10" 6 Pcs.



CHEF KNIVES • CUTLERY



Measurements Are Blade Length



Richardson
Sheffield
Since 1839

ASEAN

NEW

MOV
steel

ROUND
BACK



EXTRA
SHARP



Max 140 degrees Fahrenheit;
Phosphate free; low salt

This modern yet efficient pattern features a high quality 18/10 stainless steel handle for those who prefer stainless handles. The blade is made with the highest quality MOV steel offering superior performance and corrosion resistance.

NEW

ASEAN



Richardson
Sheffield
Since 1839



FN181 Paring Knife 3.5" 6 Pcs.



FN182 Utility Knife 5" 6 Pcs.



FN183 Flexible Sole Knife 7" 6 Pcs.



FN184 Santoku 7" 6 Pcs.



FN185 Flexible Carving Knife 8" 6 Pcs.



FN186 Chef Knife 8" 6 Pcs.



CHEF KNIVES • CUTLERY



Measurements Are Blade Length



Richardson
Sheffield
Since 1839

UNIVERSAL

NEW



A traditional design made with MOV steel and a high-quality ABS handle is a must have in any professional kitchen. The rounded back of the blade offers optimum comfort during use. A broad range including a sharpener to keep the perfect cutting edge.



ROUND
BACK



EXTRA
SHARP



Max 140 degrees Fahrenheit;
Phosphate free; low salt



FN201 Boning Knife 5" 6 Pcs.



FN202 Sticking Knife 6.5" 6 Pcs.



FN203 Carving Knife 7" 6 Pcs.



FN204 Flexible Sole Knife 7" 6 Pcs.



FN698 Universal Chef Knife 8" 6 Pcs.



Measurements Are Blade Length Except Cleaver

NEW

UNIVERSAL



Richardson
Sheffield
Since 1839



FN206 Butcher Knife 8" 6 Pcs.



FN208 Bread Knife 8" 6 Pcs.



FN207 Butcher Knife w/ Notches 10" 6 Pcs.



FN209 Ham/Salmon 10" 6 Pcs..



FN210 Cleaver 12" 6 Pcs.



FN205 Carving Fork 12 3/4" 6 Pcs.



FN211 Poultry Shears 10" 6 Pcs.

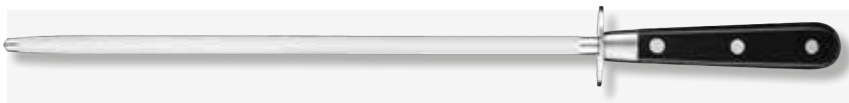

FN212 Sharpener 12" 6 Pcs.



FN213 Genoise Knife 12" 6 Pcs.



FN214 Kebab Knife 16" 6 Pcs.



Measurements Are Blade Length Except Cleaver



CHEF KNIVES • CUTLERY



Richardson
Sheffield
Since 1839

ORIGIN

NEW



Origin has a perfect balance for a knife that is ideally suited for any butcher, caterer, even the most demanding one! Origin is associated with quality and reliability. From a paring knife to a Chef's knife and everything in between, Origin has everything you need in one collection.



ROUND
BACK



EXTRA
SHARP



FN187 Paring Knife 4" 6 Pcs.



FN188 Boning Knife 5" 6 Pcs.



FN189 Flexible Fillet Knife 11 1/16" 6 Pcs.



FN190 Carving Knife 8" 6 Pcs.

Max 140 degrees Fahrenheit;
Phosphate free; low salt



Measurements Are Blade Length

NEW

ORIGIN



Richardson
Sheffield
Since 1839



FN192 Carving Fork 12 7/16" 6 Pcs.



FN193 Santoku 7" 6 Pcs.



FN194 Chef Knife 6" 6 Pcs.



FN195 Chef Knife 8" 6 Pcs.



FN196 Chef Knife 10" 6 Pcs.



FN197 Chef Knife 12" 6 Pcs.



FN198 Sharpener 9.5" 6 Pcs.



FN199 Carving Knife 10" 6 Pcs.



FN200 Ham/Salmon Knife 11" 6 Pcs.

CHEF KNIVES • CUTLERY ★ ★ ★



Measurements Are Blade Length



**Richardson
Sheffield**
Since 1839

PRO FLEX

NEW

STEEL



C A P



Max 140 degrees Fahrenheit;
Phosphate free; low salt



FN215 Triangle Spatula 5" 6 Pcs.

**HACCP
system**

Hazard Analysis Critical Control Point (HACCP)

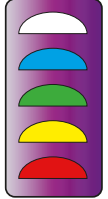

White: Milk

Blue: Seafood

Green: Processed or Cooked Meat

Yellow: Chicken

Red: Raw Meat



FN217 Wide Angled Spatula 6" 6 Pcs.



FN218 Narrow Angled Spatula 10" 6 Pcs.

5 HACCP Inserts, Multiple Colors To
Designate Usage & Avoid Cross
Contamination



FN219 Wide Angled Spatula 11" 6 Pcs.

Uses:

- ✓ Smoothing creams, pastry, icing, etc.
- ✓ Lifting and flipping crepes and pancakes
- ✓ Grill, meat cooking , planchas, etc.



FN220 Straight Spatula 6" 6 Pcs.

Pro Flex Features:

- ✓ Stainless Steel
- ✓ PP Handle



FN221 Straight Spatula 8" 6 Pcs.



FN222 Straight Spatula 10" 6 Pcs.



FN223 Straight Spatula 12" 6 Pcs.



FN224 Straight Spatula 14" 6 Pcs.



FN225 Straight Spatula 16" 6 Pcs.

CHEF KNIVES • CUTLERY



NEW

R CUT



Richardson Sheffield
Since 1839

MOV
steel



EXTRA
SHARP



Max 140 degrees Fahrenheit;
Phosphate free; low salt



SOLD AS SETS OF 2

The R Cut Collection offers a range of essential small knives in trendy colors and different blade designs. The blades are made of MOV steel.

- ✓ High Quality Stainless Steel
- ✓ Tapered Grinding/ Stone Finishing
- ✓ Dishwasher Safe
- ✓ PP Handle



FN229 Paring Knife 7 7/8" 5 Pcs.



FN228 Tomato Knife 9 1/16" 5 Pcs.



FN227 All Purpose Knife (Grey) 9 1/4" 5 Pcs.



FN226 All Purpose Knife w/ Serration (Green) 9 1/4" 5 Pcs.



CHEF KNIVES • CUTLERY



PHOTO COURTESY OF TASTING ALLIANCE

TAKE ADVANTAGE OF OUR STOCKED DECORATED ITEMS



D1CM5312
Vin with pour line (12 Oz.)
H: 7 1/2" T: 3"
B: 3" M: 3 3/8"
2 Dz.
6 Oz. Bottom of Vin
8 Oz. Top of Vin
Approximate Pour Lines



L0571
Tall Wine with pour line (16 Oz.)
H: 8 3/8" T: 2 3/4"
B: 3" M: 3 1/2"
2 Dz.
6 Oz. Bottom of Grapes
9 Oz. Top of Grapes
Approximate Pour Lines



Q1069
Corkscrew Universal (16 Oz.)
H: 9" T: 2 3/8"
B: 3 1/4" M: 3 3/16"
1 Dz.
6 Oz. Bottom of Corkscrew
9 Oz. Top of Corkscrew
Approximate Pour Lines

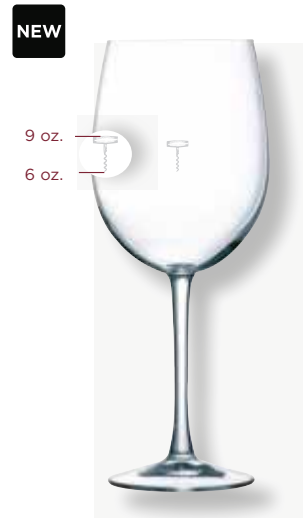

Q1095
Corkscrew Wine (16 Oz.)
H: 8 3/8" T: 2 7/8"
B: 3" M: 3 3/8"
1 Dz.
6 Oz. Bottom of Corkscrew
9 Oz. Top of Corkscrew
Approximate Pour Lines

Custom Decorated Glassware is a great way to increase the perceived value of a visit to your establishment
—AND TO STAND OUT FROM THE COMPETITION.

Decorated glass draws attention to your beverage selections. If combined with a take home program, it is an especially
EFFECTIVE MARKETING METHOD.

**PERFECT WAY TO CONTROL THE POUR*,
which translates to SIGNIFICANT COST SAVINGS.**

**Pour lines are approximate and should not be used as an exact measurement.*

To find out how simple and easy the process can be contact your Arc Cardinal representative or send an email to:
custom.deco@arc-intl.com.





Gold Rim



Silver Rim



Green Rim



Red Rim

All of our white ceramic dinnerware patterns can be decorated. With wide options, including but not limited to, banding - like you see on this page - logos can also be applied in the well or around the rim. The choices are endless!

Minimum Order Quantity 12 Dz.

All pieces are custom and made to order.

For Pricing Contact Us at:
CardinalPricing@arc-intl.com

CUSTOM DECORATION

Contact your
Arc Cardinal
Tabletop Consultant
for more ideas or examples!



Metalware Decorating

WE CAN ALSO DECORATE OUR SHAKERS!



ETCHED DECORATION



LASER DECORATION

Flatware and Steak Knife Decorating*

*LASER DECORATION ONLY



LASER INTO THE BLADE



LASER W/ BLACK FILL



LASER INTO THE HANDLE

Keep N Box, So Urban and Stack Bowl Decorating*

*LASER DECORATION ONLY



CUSTOM DECORATION

Minimum Order Quantity 24 Dz.

Not all flatware patterns can be decorated due to surface and/or handle, please inquire about specific patterns.

All pieces are custom and made to order.

For Pricing Contact Us at: CardinalPricing@arc-intl.com



FN282*
Acacia Wood MD Rectangle Handled Board
L: 18 ¼" W: 4 ¾"
4 Pcs.



FN283*
Acacia Wood LG Rectangle Handled Board
L: 21 ½" W: 5 ½"
4 Pcs.



FN284*
Acacia Wood Square Handled Board
L: 14 ⅞" W: 10"
4 Pcs.

***HAND WASH ONLY**

GLASSWARE & DINNERWARE OPTIONS THAT FIT ACACIA WOOD BOARDS

INNER CIRCLE 2" - 2 ⅛"

ARCOROC

SKUs

- L6942**- Be Bop Mug (3 ¼ Oz.)
- ES002**- Monroe Stemless Cocktail (8 Oz.)
- 79728**- Shetland Hi Ball (12 Oz.)
- C8303**- Perfection Tumbler (15 Oz.)
- J4094**- Gotham Rocks (4 ½ Oz.)
- H4623**- Malea Rocks (10 Oz.)
- P6284**- Perfection Tumbler (12 Oz.)
- FM120**- Outdoor Perfect Stemless Wine (15 Oz.)
- N5933**- Upcycle Jar Bowl (4 Oz.)
- R0741**- Appetizer Deep Bowl (5 Oz.)
- FJ834**- Capitale Coffee Mug (14 ½ Oz.)
- FJ820**- Capitale Bouillon Cup (8 Oz.)



SKUs

- G3658**- Cabernet Hi Ball (7 ¾ Oz.)
- U1032**- Open Up Warm Tumbler (10 Oz.)
- N6675**- Arpege Blue DOF (12 Oz.)
- G3322**- Primary DOF (12 Oz.)
- L6772**- Arpege DOF (12 Oz.)
- G3368**- Lima Hi Ball (12 ¾ Oz.)
- N0834**- Macaron Rocks (13 ½ Oz.)
- G3323**- Primary Beverage (14 ¾ Oz.)
- FM559**- Eternity Plus Apex Mug (12 Oz.)
- FM537**- Eternity Plus Bouillon/ Sugar (7 ¾ Oz.)

OUTER CIRCLE 3 ⅝" **



SKUs

- L3963**- Fluid Carafe (16 ¾ Oz.)
- L5636****- Sequence Burgundy (20 ½ Oz.)
- L5637****- Sequence Bordeaux (26 Oz.)
- FJ035****- Cabernet Bordeaux (21 ¼ Oz.)

**For Added Stability, Place Glass Once On Table

GLASSWARE CARE & HANDLING

Elegant dinnerware, shining cutlery, fresh linens and sparkling glassware make an impression on your customers that is almost as important as what is on your menu. As such, high-quality tableware is a big investment — protecting and maintaining this investment is essential to the success of your operation.

Thermal shock (sudden temperature change causing stress and often resulting in breakage) and mechanical shock (impact causing chipping, cracking, or breakage) are the primary factors affecting the lifecycle of glassware.

Foodservice glassware absorbs thermal and mechanical shocks on a daily basis. Eventually, it will give in to the buildup of these shocks, and breakage will occur. If your glassware shows the wear and tear of rigorous use, it should be retired — before it can break in-service or otherwise affect your customers' opinion of your operation.

Glassware DO'S

ALWAYS separate glassware, dinnerware and flatware bus tubs.

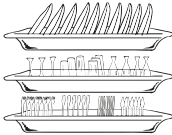

ALWAYS use an ice scoop to fill glasses with ice

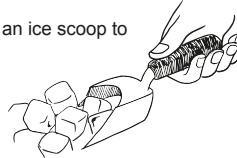

ALWAYS stack items specially marked as stackable



ALWAYS allow freshly washed glasses to return to room temperature before going back into service



ALWAYS preheat glasses used for warm drinks with warm water.



ALWAYS remove chipped or cracked glassware from service for safety reasons.



ALWAYS load glassware into a plastic storage rack.



ALWAYS use the proper racks for each glass.



ALWAYS remove ice and beverage before placing glass in bus tub to allow the glass to return to room temperature before dishwashing (to avoid thermal shock).

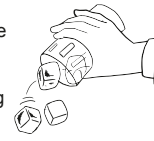

ALWAYS keep the proper amount of par levels for the operation.

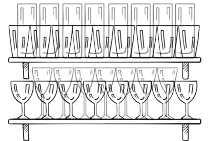

Glassware DONT'S

NEVER mix glassware, dinnerware and flatware in the same bus tub.



NEVER scoop ice with glasses.

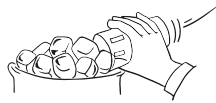

NEVER stack glasses that are not marked stackable.



NEVER use dishwasher warm glass for serving cold beverages

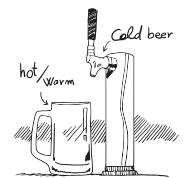

NEVER have glass to glass contact—avoid picking more than 1 glass up at once.



NEVER put flatware into glasses.



NEVER allow the glass to make contact with the beer tap.

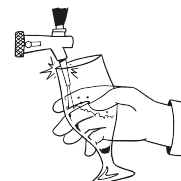

NEVER allow glassware to remain soiled overnight or for long periods (max 2 hours).



Because no two restaurants are the same, daily usage, handling practices and results will vary. For more information on care and handling, please contact your Arc Cardinal representative or call our customer service department at 973-628-0900.

DINNERWARE CARE & HANDLING

Foodservice dinnerware handles a heavy workload — and while Arc Cardinal builds dinnerware for such usage, there are some simple steps that can be taken to significantly prolong the life and look of these products. The following guidelines cover various troubleshooting and maintenance ideas that are applicable to all types of dinnerware.

Dinnerware DO'S

ALWAYS use a plastic scraper, sink sprayer or gloved hand to remove stubborn food.

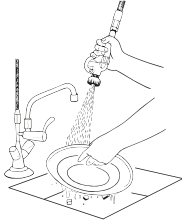

ALWAYS use proper dish racks for plates and hollowware items during dish washing.

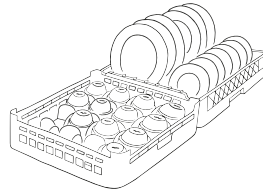

ALWAYS have your commercial dishwasher serviced regularly to ensure proper water balance and rinse aid.



ALWAYS separate dinnerware from glassware and flatware in bus buckets.

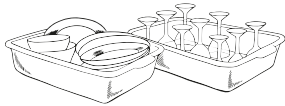

ALWAYS allow dinnerware to cool after dishwashing to room temperature and thoroughly dry before storing or putting back in service.

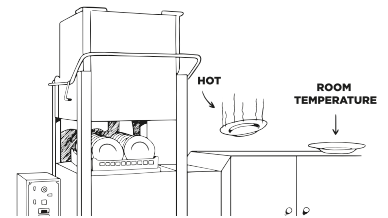

Dinnerware DONT'S

NEVER bang dinnerware on waste can or warewashing table to avoid chipping and damage to dinnerware.

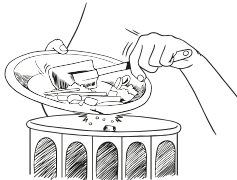

NEVER use metal pads, steel wool or abrasive cleaners.

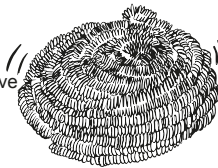

NEVER stack dishes more than 1 ft. high.



NEVER overload bus buckets.

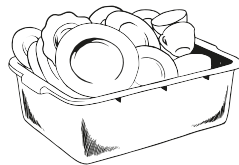

NEVER leave soiled dinnerware overnight to avoid staining of surfaces from certain beverages and sauces.

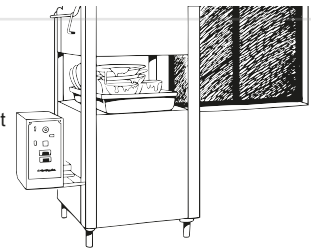

Arc Cardinal Five-Year Edge Chip Warranty

Select Chef & Sommelier and Arcoroc collections offer a five-year edge chip warranty as standard on ALL pieces within the collections — yes, including the squares, rectangles and cups — yes, everything. (Conditions available upon request.)

FLATWARE CARE & HANDLING

Strict adherence to specifications and stringent quality controls at each stage of production make Chef & Sommelier, Sola and Arcoroc flatware resistant and reliable. We meticulously scrutinize our items to ensure they are of the correct gauge, an important guarantee of durability.

Arc Cardinal offers flatware made from **18/10 stainless steel** and is designed to withstand intensive use and industrial dishwasher conditions. Whether classic or modern, you will find the Chef & Sommelier, Sola, or Arcoroc pattern that fits your needs in terms of aesthetics and user requirements. For your peace of mind, our 18/10 products come with a 10-year guarantee, applicable in case of any defect in the materials or production. This guarantee is only valid if all recommendations for use (listed below) are followed. Damage due to normal wear and tear, an accident, improper use, excessive use of detergents or use of non-compliant detergents is not covered by this guarantee. This does not cover discoloration, scratching or staining.

Flatware DO'S

ALWAYS separate flatware from other items in the bus tray.

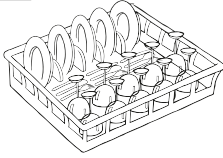

ALWAYS rinse flatware after use before loading in the dishwasher.

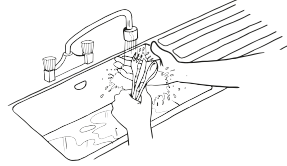

ALWAYS empty dishwasher immediately after completion of cycle and dry flatware with a soft cloth.

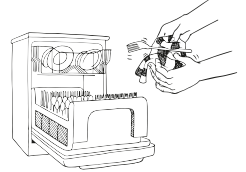

ALWAYS store flatware in a dry place.

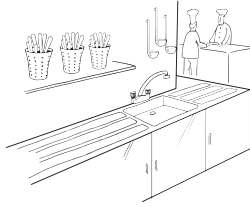

ALWAYS use the proper flatware racks for ware-washing to encourage water to dry/drain quickly and minimize scratching.

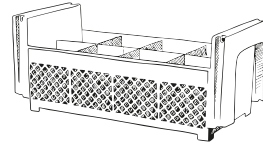

Flatware DONT'S

NEVER use detergent with lemon or other citrus added.



NEVER wash silver and stainless together to avoid discoloration.

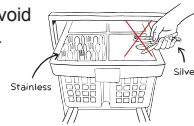

NEVER use silver cleaner to wash stainless.



NEVER use flatware for cooking as intense heat could damage the flatware.

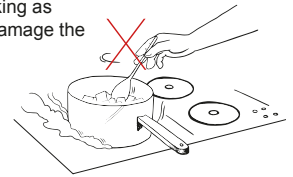

PAKKAWOOD CARE & HANDLING

- Dishwasher not recommended
- Do not use any form of chlorine bleach which will discolor
- Do not use pre-soak
- Dry immediately after washing
- Do not soak in water
- Do not use cleaning solutions containing ammonia or lemon
- Do not use steel wool to clean
- To maintain wood appearance, rub a little food safe oil on the handles monthly

FLATWARE PAR LEVELS

To calculate standard usage quantities for your establishment, select the appropriate type of operation, and then simply multiply the number of seats by the number listed below.

Example:

- 125 Seat Fine Dining Restaurant x Teaspoon (5) = 625 Teaspoon recommended order quantity.
- 100 Seat Fine Dining Restaurant x Iced Tea Spoon (1 1/2) = 150 Iced Tea Spoon recommended order quantity.
- 200 Seat Upscale Casual Restaurant x Dinner Knife (2) = 400 Dinner Knife recommended order quantity.

Item	Segment		
	Fine Dining	Upscale Casual	Catering
Teaspoon	4	3	3
Dessert or Soup Spoon	2	2	3
Tablespoon	¼	¼	-
Iced Teaspoon	1 ½	1	-
Demitasse Spoon	2	1	2
Utility/Dessert Fork	2	1 ½	2
Dinner Fork	2	2	3
Oyster or Cocktail Fork	2	1	1 ½
Dinner Knife	2	2	3
Utility/Dessert Knife	2	1 ½	2
B&B Knife or Butter Spreader	2	2	3

DINNERWARE PAR LEVELS

To calculate standard usage quantities for your establishment, select the appropriate type of operation, and then simply multiply the number of seats by the number listed below.

Example:

125 Seat Fine Dining Restaurant x 10 1/4" – 10 3/8" Dinner Plate (2) = 250 Plate recommended order quantity.

100 Seat Fine Dining Restaurant x Coffee/Tea Cup (3) = 300 Cup recommended order quantity.

200 Seat Upscale Casual Restaurant x 5 1/2" – 6 5/8" Bread Plate (2) = 400 Plate recommended order quantity.

Item	Segment			
	Fine Dining	Upscale Casual	Catering	Banquet
Bread & Butter Plates	2	2	2	6
Salad/ Dessert Plates	2	2	2	-
Lunch Plate	2	2	2	2
Dinner Plate 9 3/4" - 10"	3	1 1/2	1 1/2	2
Dinner Plate 10 1/4" – 10 3/8"	2	2	2	-
Platters 7 1/4" – 9 7/8"	1 1/2	1	1	-
Platters 11" - 15"	1 1/2	1	1	1 1/2
Coffee/Tea Cup	3	3	2	2
Bouillon, Handled or Non-handled	1	1 1/2	1 1/2	1 1/2
Mug	2	2	2	2
Saucers	3	3	2	2
Fruit Dish	3	2	2 1/2	6
Grapefruits	1	1	1	1 1/4
Cereal Bowl	1	1	1	1/2
Rim/Deep Soup	1/2	1/2	1/2	-
Coffee/Tea Pot	1/2	1/2	1/2	-
Creamer (Pitcher)	1/2	1/2	1/2	-
Service Plate	1 1/2	1 1/2	1 1/2	-

GLASSWARE PAR LEVELS

To calculate standard usage quantities for your establishment, select the appropriate type of operation, and then simply multiply the number of seats by the number listed below.

Example:

125 Seat Fine Dining Restaurant x 11 Oz. Water (3) = 375 Glass recommended order quantity.

200 Seat Banquet x 8 1/2 Oz. Wine (1 1/2) = 300 Glass recommended order quantity.

100 Seat Upscale Casual Restaurant x 12 Oz. Iced Tea (1 1/2) = 150 recommended glass order quantity.

Item	Segment		
	Fine Dining	Casual Upscale	Banquet
Old Fashioned / Rocks 8 1/2 Oz.	3	3	2
Double Rocks / DOF 10 1/2 - 14 Oz.	3	3	2
Beverage 12 1/2 Oz.	3	3	2
Beer 16 Oz.	2	2	2
Wine 8 1/2 Oz.	2	3	2
Flute 6 Oz.	2	3	2
Cocktail 7 1/2 Oz.	1 1/2	2	1 1/2
Cocktail 10 Oz.	1 1/2	2	1 1/2
Margarita 12 - 14 Oz.	1 1/2	1 1/2	1 1/2
Shot 1 1/4 Oz.	1 1/2	1 1/2	1 1/2
Cordial 4 Oz.	1 1/2	1 1/2	1 1/2
Juice 5 - 6 Oz.	1 1/2	1 1/2	1 1/2
Water / All Purpose 11 - 14 Oz.	3	3	3
Iced Tea 12 - 16 Oz.	1 1/2	1 1/2	1 1/2
Wine 16 - 20 Oz.	1	1	1
Flute 5 3/4 Oz.	2	3	3

WARRANTY – Limited 2 Year Warranty

Products manufactured by Richard Sheffield will be replaced by our company returned by the original owner due to defects in workmanship and material within 2 year of the purchase date. In the unlikely event of this happening please return the product to the original place of purchase with proof of receipt. A replacement piece or a similar replacement piece will be sent if the pattern is no longer available. This warranty does not cover any damage or defects caused by accidental damage, normal wear and tear, misuse, abuse, or failure to follow the proper care instructions provided.

Care & Use

Culinary mastery requires excellent tools. Whether you're a novice cook or an experienced chef, Richardson Sheffield knives will help you prepare every dish!

Care instructions for chef knives quality is very important. Richardson Sheffield products are made from high quality stainless steel, which gives them great corrosion resistance (resistance against rust) and makes the products dishwasher safe. However, we highly recommend washing by hand to keep them in optimal condition. If you do want to clean the knives in the dishwasher, we advise you to follow the care instructions below to keep your knives in good condition and to prevent staining.

- Wash all products before you use them for the first time.
- Always rinse your kitchen knives with water after use and before placing them in the dishwasher.
- Remains of food, salt, mineral salts (present in tap water), vinegar, bleach and harsh detergents can cause stains or pitting if the knives are not cleaned thoroughly after use of these products.
- Do not use too much detergent or rinse aid, because these are corrosive in high concentrations.
- Never leave the kitchen knives soaking in water for a longer period of time.
- Given the possibility of 'contact corrosion' (caused by contact between various types of metal), we recommend packing the knives separately from forks and/or spoons in the cutlery basket.
- Place the knives with their blades pointing upwards in the dishwasher.
- When the cleaning programme is finished, open the door to prevent condensation forming on the knives. Preferably, remove the knives from the dishwasher and dry them with a soft cloth or towel.



BEFORE USE

- Wash in hot water, rinse and dry thoroughly before first use.
- We recommend pre-seasoning. Even pre-seasoned cast iron can use some extra protection.
- To season your pan, heat it up on the stove top until its hot, then rub a little oil into it and let it cool.
- Clean it after each use.
- Pre-season as needed.

CLEANING & CARE

- Let pans cool before washing in warm water. Soak first in warm water and detergent to remove burnt on food.
- Always use wooden, plastic or silicone utensils, avoid metal.
- Do not tap the edges of the container & never cut food inside the cookware as you risk scratching or damaging the enamel.
- Use non-abrasive nylon scourers.
- Always dry thoroughly before storing.
- Avoid the use of a dishwasher after every use to prolong the longevity of the product.
- Heating in the oven may cause the metal knobs to change color slightly.

Arc Cardinal Items that Fit Trivets

Items that Fit FN976 (Round Trivet)

FN421- Mini Round Matte Black Casserole 0.37 Q (11 7/8 oz.)

FN422- Mini Round Matte Ruby Casserole 0.37 Q (11 7/8 oz.)

FN423- Mini Round Matte Black Casserole 0.63 Q (20 1/4 oz.)

FN424- Mini Round Matte Ruby Casserole 0.63 Q (20 1/4 oz.)

P0310- Smart Cuisine Creme Brulee Dish (9 1/2 oz.)

FJ821- Capitale French Onion Soup Crock Bowl (12 oz.)

Items that Fit FN977 (Oval Trivet)

FN417- Round Matte Black Dish 5 7/8" (15 cm)

FN418- Round Matte Black Dish 7 1/8" (18 cm)

Items that Fit FN978 (Oval Trivet)

FN419- Oval Matte Black Dish 7 7/8" x 5 7/8" (20 cm)





CARE AND USE GUIDE

VACUUM INSULATED STAINLESS STEEL CARAFE

GENERAL CARE

- Before first use, and as soon as possible after each use, wash all parts with warm, soapy water. Rinse all parts thoroughly and allow time to dry. Store with stopper off.
- Contents should not be left in the container for longer than 24 hours. As soon as possible after each and every use, wash all parts with warm, soapy water. Rinse all parts thoroughly with clean water. Allow all parts to dry completely prior to next use or storage.
- DO NOT use abrasive soaps, scouring pads, brushes, or other objects to clean inside of container.
- DO NOT use abrasive cleaners or scrubbers to clean outside of product since they may dull finish.
- This product is top-rack dishwasher safe; however, hand washing is recommended as the dishwasher uses harsher detergents and hot water that may affect the appearance of your product.
- Residual liquids, foods, or other contents may become trapped between product components, such as lid parts, container parts, gaskets (flexible band around lid and/or stopper), or straws (if present in the product). Although this product is top-rack dishwasher safe, hand washing is recommended to ensure that these parts of the product are thoroughly cleaned.
- For maximum thermal efficiency, preheat or pre-chill the product just prior to use. Fill with hot/cold tap water, attach lid, let stand 5 to 10 minutes and empty water. After filling container with contents, re-cover with lid to increase thermal efficiency. Never use a microwave, conventional oven, or other heat source for this purpose.

ASSEMBLY & USE

TWIST-AND-POUR STOPPER (IF PRESENT):

1. Remove stopper (A) by twisting counterclockwise.
2. Remove gasket(s) (B and B1 - if present) from underside of stopper (A).
3. Wash all parts separately, then re-assemble. Ensure gasket(s) (B and B1 - if present) are properly seated to minimize leaking.

* Image for reference only: actual product may vary

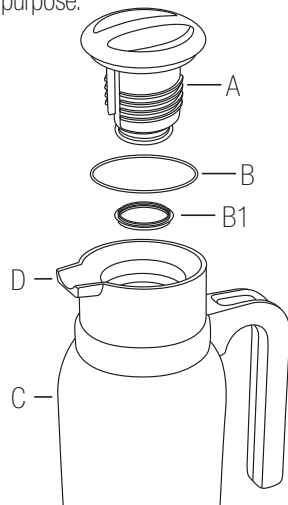

4. Fill container (C) with contents. Do not overfill: Leave space for the stopper (A), to avoid overflow.
5. Replace stopper (A) by twisting clockwise.
6. To pour, twist stopper (A) counterclockwise ½ - 1 turn. Orient product so that pour indicator arrow is pointing in-line with spout (D). Proceed to pour. Note: Stopper does not need to be removed completely to pour contents.
7. Re-tighten stopper (A) by twisting clockwise.

PUSH-BUTTON STOPPER (IF PRESENT):

1. Remove stopper (E) by twisting counterclockwise.
2. To disassemble, lift up on stopper-tab (K) of stopper-cover (L) until completely removed.
3. Depress and twist washer (M) clockwise until it aligns with washer-post (Q). Washer-spring (N) will naturally release washer (M).
4. Remove washer-spring (N).
5. Remove valve-plate (R) and valve-spring (P) by pulling downward on base of valve-plate (R).
6. Remove gaskets (H and I).
7. Wash all parts separately, then re-assemble. Ensure gaskets (H and I) are properly seated to minimize leaking.
8. Fill container (G) with contents. Do not overfill: Leave space for the stopper (E), to avoid overflow.
9. Replace stopper (E) by twisting clockwise. Depress the push-button (O) 2 to 3 times to release pressure.
10. Securely grip handle (J) and press push-button (O).
11. Tilt product and pour contents through spout (F).
12. Bring product to an upright position and release push-button (O).

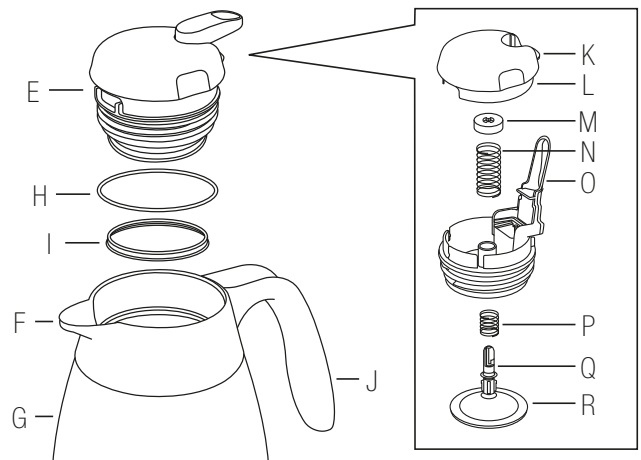



CARE AND USE GUIDE

VACUUM INSULATED STAINLESS STEEL CARAFE

GENERAL CARE

- Before first use, and as soon as possible after each use, rinse all parts with warm, soapy water. Rinse thoroughly with fresh water and allow time to dry. Store with stopper off.
- Contents should not be left in the container for longer than 24 hours. As soon as possible after each and every use, wash all parts with warm, soapy water. Rinse all parts thoroughly with clean water. Allow all parts to dry completely prior to next use or storage.
- DO NOT use abrasive cleaners or scrubbers to clean outside of product since they may dull finish.
- DO NOT use bleach or cleaners containing chlorine on any parts of product.
- HANDWASH ONLY - this product is not dishwasher safe.
- DO NOT immerse or soak in water for prolonged periods of time. Residual liquids, foods, or other contents may become trapped between product components, such as lid parts, container parts, gaskets (flexible band around lid and/or stopper), or straws (if present in the product). Hand washing is recommended to ensure that all parts of the product are thoroughly cleaned.
- For maximum thermal efficiency, preheat or pre-chill the product just prior to use. Fill with hot/cold tap water, attach lid, let stand 5 to 10 minutes and empty water. After filling container with contents, re-cover with lid to increase thermal efficiency. Never use a microwave, conventional oven, or other heat source for this purpose.

PUSH-LEVER LID (IF PRESENT):

1. Remove lid (A) by twisting counterclockwise.
2. Wash all parts separately, then re-assemble. See General Care section above for washing instructions.
 - a. Ensure gaskets (if present) are properly seated to minimize leaking.
3. Fill container with contents. Do not overfill: Leave space for the lid (A) to avoid overflow.
4. Replace lid (A) by twisting clockwise. Depress the push-lever (A1) 2 to 3 times to release pressure.
5. To pour, securely grip handle (B) and press push-lever (A1).
6. Tilt product and pour contents through spout (A2).
7. Bring product to an upright position and release push-lever (A1) to close.

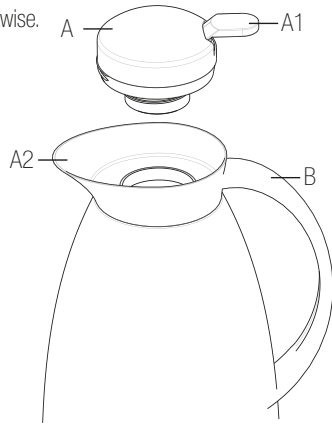

HINGED LID (IF PRESENT):

1. Lift lid (A) by pressing on the hinge lever (A1).
2. Wash all parts. See General Care section above for washing instructions.
3. Before filling, open lid (A) all the way. Fill container with contents.
 - a. Do not overfill: Leave space for the lid (A) to avoid overflow.

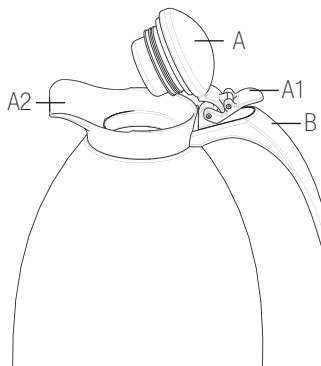

Image for reference only: Actual product may vary.

4. To pour, securely grip handle (B) and press and hold hinge lever (A1). Hinge lever (A1) must be held while pouring to ensure easy flow of contents.
5. Tilt product and pour contents through spout (A2).
6. Bring product to an upright position and release hinge lever (A1).
7. To close, press down on the lid (A) into the lid opening until the lid (A) is secure.
 - a. Hinge lever (A1) may need to be adjusted to better align the lid and lid opening.

CARE AND USE GUIDE

GLASS VACUUM INSULATED CARAFE

EN

GENERAL CARE

- Before first use, and as soon as possible after each use, rinse all parts with warm, soapy water. Rinse thoroughly with fresh water and allow time to dry. Store with stopper off.
- Contents should not be left in the container for longer than 24 hours. As soon as possible after each and every use, wash all parts with warm, soapy water. Rinse all parts thoroughly with clean water. Allow all parts to dry completely prior to next use or storage.
- DO NOT use abrasive cleaners or scrubbers to clean outside of product since they may dull finish.
- DO NOT use bleach or cleaners containing chlorine on any parts of product.
- HANDWASH ONLY - this product is not dishwasher safe.
- DO NOT immerse or soak in water for prolonged periods of time. Residual liquids, foods, or other contents may become trapped between product components, such as lid parts, container parts, gaskets (flexible band around lid and/or stopper), or straws (if present in the product). Hand washing is recommended to ensure that all parts of the product are thoroughly cleaned.
- For maximum thermal efficiency, preheat or pre-chill the product just prior to use. Fill with hot/cold tap water, attach lid, let stand 5 to 10 minutes and empty water. After filling container with contents, re-cover with lid to increase thermal efficiency. Never use a microwave, conventional oven, or other heat source for this purpose.

PUSH-LEVER LID (IF PRESENT):

1. Remove lid (A) by twisting counterclockwise.
2. Wash all parts separately, then re-assemble. See General Care section above for washing instructions.
 - a. Ensure gaskets (if present) are properly seated to minimize leaking.
3. Fill container with contents. Do not overfill: Leave space for the lid (A) to avoid overflow.
4. Replace lid (A) by twisting clockwise. Depress the push-lever (A1) 2 to 3 times to release pressure.
5. To pour, securely grip handle (B) and press push-lever (A1).
6. Tilt product and pour contents through spout (A2).
7. Bring product to an upright position and release push-lever (A1) to close.

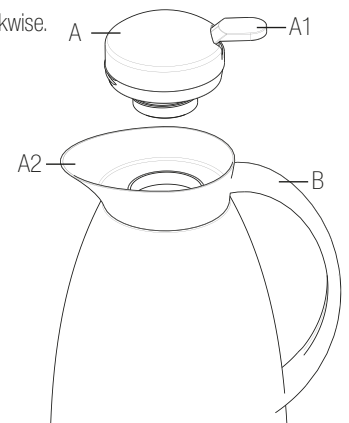

GLASSWARE

Item #	Page
00016	103
00187	123
00213	41 , 92
04757	40
04900	113
07131	109
07132	109
07134	109
10007	78
10291	119
12652	83 , 100
12926	40
13297	85
14798	20 , 104
15012	67
17198	78
19188	103
19343	110
19415	113
19416	113
20864	63
20865	63
20866	63
20867	63
20868	63
20869	63
20871	63
20873	63
20874	63
20875	63
21053	113
21554	103
22032	111
24668	111
25263	113
25275	113
29337	211 , 216
29811	89
33040	119
36229	113
37159	77
37264	44
37298	44 , 97

Item #	Page
37405	44
37413	44
37439	44
37652	44 , 93 , 97
40375	83 , 103
42258	105
42440	64
43100	110
43279	64
43281	64
43716	110
43745	89
43746	89
46981	19
47017	19
47346	78 , 103
48024	20 , 95
49357	111
50143	44
51257	123
52643	110
53195	85
53205	77
53214	77
53224	77
53232	77
53404	115
53664	62
53673	119
53675	119
55239	122
55878	123
56416	44 , 97
57069	62
57070	43
57286	43
60024	62
60440	62
61697	62
61698	62
62451	117
62664	105
71075	39
71076	40

Item #	Page
71078	40
71079	40 , 105
71080	39
71081	40 , 91
71083	39
71084	39
71086	39 , 97
71092	40
71093	40 , 91
75926	62
76495	89
79320	41 , 92
79698	76
79728	76
79736	76
79747	76
06942	41
07395	41
09232	41 , 92
46888	18
46961	17
46973	17
46978	17
47019	19
47026	19
50816	17
BHA49	84
C0198	119
C0790	115
C1320	123
C1643	115
C3544	109
C3966	103
C5872	111
C8303	77
C8304	77
C8832	77
CA008	124
CA030	93
CA031	93
CA364	84
CA504	93
CAP01	126
CAP02	127

GLASSWARE

Item #	Page
CAP04	126
CAP05	126
CAP06	126
CAP07	124
CAP08	126
CAP09	125
CAP11	126
CAP12	124
CAP14	126
CAP18	125
CAP20	125
CAP28	125
CAP32	126
CAP51	126
CHA36	84
CO678	122
D0129	113
D0130	88
D0795	18
D0796	21 , 95
D1C08365	119
D1CM5312	39 , 292
D2024	41 , 91
D2138	117
D2142	117
D2443	115
D6315	62
D6653	117
E1513	55
E1514	55
E1515	55
E1907	76
E1908	89
E2788	19
E2789	19
E2790	19 , 106
E3559	42
E3562	42
E5358	20 , 104
E5458	88 , 110
E6124	122, 129
E6125	97, 129
E6127	91 , 129
E6128	91 , 129

Item #	Page
E6131	129
E6132	92 , 129
E6133	129
E6134	129
E6136	129
E6137	129
E6138	129
E6139	129
E6140	129
E6141	113, 129
E6250	20 , 95
E7254	122
E7255	122
E7258	122
E7695	31
E7696	31
E7697	31
E7698	31
E7700	31 , 95
E8792	110
ES001	89 , 92
ES002	89 , 92
FE644	119
FG688	115
FH517	123, 124
FH998	122
FJ001	122
FJ002	119
FJ003	119
FJ004	119
FJ014	118
FJ015	118
FJ016	118
FJ035	17
FJ036	17
FJ037	17
FJ060	81
FJ061	81
FJ062	81
FJ063	81
FK203	86
FK206	86
FK209	86
FK212	87

Item #	Page
FK213	87
FK258	81
FK259	81
FK364	84
FK368	84
FK492	84
FK493	84
FK596	123, 124
FK856	115
FL012	86
FL013	86
FL014	87
FL108	87
FL200	81 , 119
FL203	81 , 119
FL337	109
FL338	109
FL470	119
FM120	129
FM400	130
FM402	130
FM403	130
FN090	131
FN091	131
FN092	131
FN093	131
FN159	11
FN160	11
FN161	11
FN162	11
FN166	11
G0036	50
G1420	105
G2639	103
G3322	50
G3323	50
G3367	49 , 99
G3368	49
G3570	21 , 107
G3573	21 , 107
G3658	47
G3659	47 , 98
G3666	47 , 99
G3674	47

GLASSWARE

Item #	Page
G3960	110
H0652	45
H0654	45
H0655	45
H0656	45 , 97
H0736	55
H2090	36 , 97
H2316	36
H2317	36
H2318	36
H3008	61
H3032	61
H3089	61 , 110
H3839	61
H3856	61 , 110
H3858	61
H4531	53
H4623	53
H4870	77
H5057	103
H5169	61
H7763	61
H8466	37 , 97
H9211	113
HS001	127
HS002	127
J0317	61
J0825	110
J1478	37 , 97
J2603	64
J2605	64
J2610	64
J2611	64
J2614	64
J3510	67
J3811	123
J4089	110
J4094	59
J4096	59
J4097	59
J4099	59
J4101	59
J4102	59
J4103	59

Item #	Page
J4104	59
J4106	110
J4168	64
J4170	64
J4226	83
J4227	83
J4238	83 , 100
J4239	83 , 101
J4241	83 , 100
J4764	67
J8742	27
J8743	27
J8821	111
J8907	27 , 95
J8908	27 , 95
J9014	27
L0371	41 , 93 , 97
L0571	18 , 292
L0996	85
L2356	49
L2369	47
L2370	47 , 99
L2609	23
L2761	23
L2762	23 , 95
L3678	23 , 90 , 94
L3963	120
L3965	121
L4193	121
L4194	120
L4212	120
L4213	120
L4257	121
L4865	88 , 110
L5275	69
L5633	13
L5635	13
L5636	13
L5637	13
L5638	13
L5640	15 , 94
L5641	15 , 90 , 94
L5642	15
L5711	111

Item #	Page
L5754	46
L5755	46
L5756	46 , 99
L5757	46 , 98
L5758	46 , 99
L6119	100 , 105 , 115
L6247	121
L6500	67
L6630	52
L6767	50
L6772	50
L6942	69
L6943	69
L7253	75 , 103
L7254	75 , 101
L7255	75
L7256	75
L7334	65
L7335	65
L7339	65
L7340	65
L7844	64
L8110	49
L8507	48 , 99
L8508	48
L8675	48
L8677	50
L8687	69
L8688	69
L8689	121
L8941	37 , 97
L8970	111
L9267	25
L9348	25
L9412	25
L9414	25
MT002	127
MT004	126
MT011	126
MT051	126
MT849	125
MT850	125
N0512	71
N0513	71

GLASSWARE

Item #	Page
N0520	71
N0521	71
N0523	71
N0524	71 , 101
N0526	71
N0527	71
N0528	71
N0529	71 , 100
N0530	71
N0531	71 , 101
N0834	46
N1738	27
N1739	23
N1744	23
N2513	85
N2644	113
N2760	92
N3950	110
N4742	23
N4907	33
N5082	33 , 97
N5163	33
N5368	23 , 107
N5812	79
N5828	79
N5831	79
N5834	79 , 103
N5993	33
N5994	53
N5995	53 , 101
N6216	92
N6374	98 , 104
N6377	83 , 101
N6640	83
N6643	83
N6675	50
N6815	21 , 90
N6831	21 , 90
N6887	21 , 90
N8172	104
N8212	104
N8279	106
N8281	106
N8901	67

Item #	Page
N8981	67
N8982	67
N9029	67
N9696	13
N9710	13
N9711	15 , 107
ODP36	130
OL166	124
OL167	124
P0089	15 , 107
P0112	19
P0776	39
P0777	39
P1470	75
P3008	111
P4187	73
P4188	73 , 101
P6284	77
P8064	92
P8494	54
P8495	54 , 101
P8496	54 , 100
P8499	54
P8500	54 , 101
P8782	35
P8790	35
P8792	35
P8793	35 , 97
P8794	35
P8795	75 , 91
P8796	75 , 93
P8821	75 , 92
P9067	73
P9411	73
Q1069	13, 292
Q1095	35 , 292
Q1151	11, 95
Q1774	67
Q2233	57
Q2234	57
Q2750	57
Q2751	57
Q2967	57
Q3702	15 , 90

Item #	Page
Q4025	121
Q4026	121
Q4033	121
Q4337	51 , 99
Q4340	51
Q4353	51 , 99
Q4354	52 , 99
Q4357	51
Q6480	67
Q7781	83
Q7932	75 , 92
RBB02	124
RBB06	124
RBBR7	124
RBDG3	124
RBO05	124
RBP01	124
RBP04	124
RBR09	124
RBW06	124
RBY03	124
U1008	29
U1010	29
U1011	29
U1012	29
U1013	29 , 106
U1032	46 , 98 , 104
U1033	46 , 99
U1051	29 , 95

DINNERWARE

Item #	Page
00556	206
01141	211
01158	211
01166	211
06626	210
08781	210
09994	206
10027	206, 207
11874	211
14611	195
22506	193
22514	194
22522	193
22530	193
22662	195
22670	195
22712	195
24742	193
25269	195
25285	195
25293	195
28891	195
29337	194
36140	195
37684	211
43121	213
43319	195
43830	206
49138	199
49139	199
49142	199
49150	199
50061	195
50998	213
53403	211
57974	193
57975	193
58010	213
58012	213
58621	193
61875	211
64733	195
67107	194

Item #	Page
73442	211
D3612	175 , 212
D9070	210
D9219	211
E8883	210
E9155	206
E9156	206
E9157	206
E9158	206, 207
E9159	207
E9160	206, 207
EB165	147
EB182	147
EB217	147
EB248	147
EB255	147
EB260	147
EB281	147
EB288	147
EB298	147
EG105	150
EG162	149
EG178	150
EG205	149
EG216	149
EG229	149
EG243	149
EG254	149
EG267	149
EG271	149
EG273	149
EG292	149
EG295	149
EG356	149
EJ105	150
EJ162	149
EJ178	150
EJ205	149
EJ216	149
EJ229	149
EJ243	149
EJ254	149
EJ267	149
EJ271	149

Item #	Page
EJ273	149
EJ292	149
EJ295	149
EJ318	149
EJ356	149
EO165	147
EO182	147
EO217	147
EO248	147
EO255	147
EO260	147
EO281	147
EO288	147
EO298	147
EO355	147
EP105	150
EP162	149
EP178	150
EP205	149
EP216	149
EP229	149
EP243	149
EP254	149
EP267	149
EP271	149
EP273	149
EP292	149
EP295	149
EP318	149
EP356	149
EP777	156
EV318	149
FF192	169
FF193	169
FF194	169
FF195	169
FF196	169
FF198	169
FF199	169
FF200	169
FF201	169
FF202	169
FH285	181
FH286	181

DINNERWARE

Item #	Page
FH287	181
FH288	181
FH289	181
FH608	181
FH609	181
FH610	181
FH611	181
FH614	181
FH615	181
FH621	181
FJ524	165
FJ525	165
FJ529	165
FJ624	165
FJ628	165
FJ629	165
FJ630	165
FJ724	165
FJ726	165
FJ729	165
FJ730	165
FJ733	165
FJ772	191
FJ774	191
FJ775	191
FJ776	191
FJ777	191
FJ778	191
FJ779	191
FJ809	191
FJ811	191
FJ812	191
FJ815	191
FJ816	191
FJ818	191
FJ819	191
FJ820	191
FJ821	191
FJ822	191
FJ823	191
FJ824	191
FJ825	191
FJ826	191
FJ827	191

Item #	Page
FJ830	191
FJ831	191
FJ832	191
FJ833	191
FJ834	191
FK546	153
FK548	153
FK639	187
FK640	187
FK641	187
FK642	187
FK643	187
FK644	187
FK645	187
FK646	187
FK763	185
FK764	185
FK765	185
FK766	185
FK767	185
FK768	185
FK769	185
FK770	185
FK774	185
FK775	185
FK777	185
FK788	153
FK789	153
FK790	153
FK843	153
FK844	153
FK846	153
FK847	153
FK848	153
FK851	153
FK888	153
FK889	153
FK890	153
FK943	153
FK944	153
FK947	153
FK951	153
FK988	153
FK989	153

Item #	Page
FK990	153
FL643	153
FL644	153
FL645	153
FL646	153
FL647	153
FL648	153
FL651	153
FM381	183
FM382	181
FM536	155
FM537	156
FM538	155
FM539	155
FM540	157
FM541	157
FM542	155
FM543	157
FM544	155
FM545	155
FM546	157
FM547	155
FM548	155
FM549	155
FM550	156
FM551	155
FM552	156
FM553	155
FM554	155
FM555	156
FM556	155
FM557	156
FM558	155
FM559	157
FM560	155
FM561	156
FM562	156
FM563	157
FM564	155
FM566	155
FM567	156
FM568	155
FM569	155
FM570	155

DINNERWARE

Item #	Page
FM713	157
FM729	145
FM730	145
FM732	145
FM733	145
FM736	145
FM737	145
FM738	145
FM739	145
FM740	145
FM741	145
FM742	150
FM743	150
FM744	150
FM745	150
FM746	150
FM747	150
FM748	150
FM749	150
FM750	150
FM751	150
FM752	150
FM753	150
FM754	150
FM755	150
FM756	150
FM757	150
FM758	150
FM759	150
FM760	150
FM761	150
FM762	150
FM763	150
FM764	150
FM765	150
FM888	155
FM900	157
FM901	157
FM902	157
FM903	157
FM904	157
FM913	149
FM914	149
FM915	149

Item #	Page
FN001	159
FN002	159
FN003	159
FN004	159
FN006	159
FN008	159
FN011	159
FN017	159
FN018	159
FN019	159
FN022	159
FN026	159
FN028	159
FN030	159
FN031	159
FN033	159
FN034	159
FN038	159
FN039	159
FN051	159
FN063	159
FN097	156
FN235	203
FN236	203
FN237	203
FN238	203
FN239	203
FN240	203
FN282	151
FN283	151
FN284	151
FN454	150
FN455	150
FN457	135
FN458	135
FN459	135
FN460	135
FN461	135
FN462	135
FN463	135
FN464	135
FN465	135
FN466	135
FN467	135

Item #	Page
FN468	135
FN469	139
FN470	139
FN471	139
FN472	139
FN473	139
FN474	139
FN475	139
FN476	139
FN477	139
FN478	139
FN479	139
FN480	139
FN481	139
FN482	139
FN483	139
FN484	139
FN485	139
FN486	139
FN487	139
FN488	139
FN489	139
FN490	139
FN491	139
FN492	139
FN493	137
FN494	137
FN495	137
FN496	137
FN497	137
FN498	137
FN499	137
FN500	136
FN501	136
FN502	136
FN503	137
FN504	137
FN505	137
FN506	137
FN507	137
FN508	137
FN509	161
FN510	161
FN511	161

DINNERWARE

Item #	Page
FN512	161
FN513	161
FN514	161
FN516	161
FN517	137
FN518	137
FN519	137
FN520	137
FN521	137
FN522	137
FN523	137
FN524	136
FN525	136
FN526	136
FN527	137
FN528	137
FN529	137
FN530	137
FN531	137
FN532	137
FN549	135
FN550	135
FN551	135
FN552	135
FN553	135
FN555	135
FN556	135
FN557	135
FN559	135
FN560	135
FN561	135
FN562	135
FN808	156
FN809	156
FN876	141
FN877	141
FN878	141
FN879	141
FN880	141
FN881	141
FN882	141
FN883	141
FN884	141
FN885	141

Item #	Page
FN897	141
FN898	141
FN899	141
FN922	141
FN923	141
FN924	141
FN928	143
FN929	143
FN930	143
FN931	143
FN932	143
FN935	143
FN940	144
FN941	144
FN942	144
FN943	144
FN946	145
FP085	143
FP086	143
FP087	143
FP088	143
FP089	143
FP090	143
FP091	144
FP092	145
FP111	144
FP112	144
G3744	171
G3745	171
G3749	171
G3751	171
G3752	171
G3753	171
G3754	171
G3765	171
G4391/ V1539	193
G4394/ V1540	193
G4396/ V1538	194
H0012	171
H0013	171
H2684	199
H2685	199
H2686	199
H2691	199

Item #	Page
HG165	143
HG182	143
HG217	143
HG248	143
HG253	143
HG255	143
HG260	143
HG281	143
HG288	143
HG298	145
HG324	143
HG355	145
HG650	143
HG725	143
HG867	143
HG975	143
HG978	143
HGC11	145
HGC13	145
HGD10	143
HGD11	143
HGR11	144
HGR13	144
HI102	143
HI111	143
HI113	145
HI145	145
HI156	145
HI227	145
HI650	143
HI725	143
HI867	143
HI975	143
HI978	143
HIC11	145
HIC13	145
HID10	143
HID11	143
HIR11	144
HIR13	144
HL001	144
HL002	144
HL165	143
HL182	143

DINNERWARE

Item #	Page
HL217	143
HL248	143
HL253	143
HL255	143
HL260	143
HL281	143
HL288	143
HL298	145
HL355	145
HN001	144
HN002	144
HN113	143
HN165	143
HN182	143
HN217	143
HN248	143
HN253	143
HN255	143
HN260	143
HN281	143
HN288	143
HN298	145
HN317	143
HN355	145
HND63	145
HND77	145
HNW10	144
HNW86	144
J0226	210
J0232	210
J0856	210
L3199	173
L3201	173
L3202	173
L3203	173
L3204	173
L3205	173
L3206	173
L3207	173
L3208	173
L4210	209
L6084	209
L6350	209
L6498	209

Item #	Page
L6687	212
L6688	212
L6689	212
L6690	212
L6691	212
L6692	212
L6753	213
L6756	213
L6850	193
L7422	209
L9548	167
L9556	167
L9557	167
L9558	167
L9561	167
L9562	167
L9584	167
L9585	167
L9603	163
L9605	163
L9606	163
L9616	163
L9617	163
L9618	163
L9619	163
L9623	163
L9624	163
L9691	167
M0090	206
N2420	209
N2608	206
N3295	201
N3567	201
N5926	174
N5928	174
N5932	174
N5933	174
N5967	166
N5968	166
N5969	166
N5970	166
N5971	166
N5973	166
N6393	193

Item #	Page
N6652	167
N7945	206
N8804	209
N9360	193
N9361	193
N9362	193
N9363	195
N9364	194
N9365	195
N9395	195
N9396	195
N9397	195
N9398	195
N9399	195
N9401	195
N9402	194
N9403	194
N9404	194
N9405	194
N9406	194
N9407	194
N9408	193
N9411	193
P0310	201
P0886	201
P0887	201
P1122	196
P1123	196
P1124	196
P1125	196
P1128	197
P1129	197
P1130	197
P1131	197
P1137	197
P1138	197
P1139	197
P1140	197
P1141	197
P3945	199
P3946	199
P3947	199
P3948	199
P3949	199

DINNERWARE

Item #	Page
P3951	199
P3962/ V1653	193
P3964/ V1536	193
P3967	194
P3979	194
P4025	201
P5516	203
P5517	203
P5520	203
P5521	203
P5522	203
P5523	203
P5842	199
P5843	199
P5844	199
P5845	199
P5846	199
P5847	199
P5849	199
P5860	199
P5862	199
P5864	199
P5865	199
P5866	199
P8332	201
P9771	195
P9772	195
P9773	195
Q0620	205
Q1745	205
Q1750	205
Q1752	205
Q1753	205
Q1757	205
Q1758	205
Q1762	205
Q2983	207
Q2984	207
Q2985	207
Q3006	205
Q3007	205
Q5214	205
Q5217	205
R0735	173

Item #	Page
R0736	173
R0737	173
R0738	173
R0739	173
R0740	173
R0741	173
R0742	173
R0743	173
R0744	173
R0745	173
R0747	173
R0748	175 , 212
R0801	183
R0802	183
R0803	183
R0804	183
R0805	183
R0806	183
R0807	183
R0809	183
R0811	183
R0817	183
R0819	183
R0830	183
R0833	183
R0835	183
R0839	183
R0840	183
R0849	183
R0850	183
R0851	183
R0852	183
R0860	183
R0882	183
R0901	189
R0902	189
R0903	189
R0904	189
R0905	189
R0906	189
R0907	189
R0908	189
R0917	189
R0918	189

Item #	Page
R0919	189
R0926	189
R0928	189
R0929	189
R0931	189
R0932	189
R0933	189
R0947	189
R0950	189
R0959	189
R0960	189
R0968	189
S0602	179
S0603	179
S0604	179
S0606	179
S0628	179
S0630	179
S0633	179
S0638	179
S1501	177
S1502	177
S1503	177
S1504	177
S1506	177
S1507	177
S1508	177
S1509	177
S1512	177
S1517	177
S1518	177
S1521	177
S1528	177
S1530	177
S1533	177
S1534	177
S1535	177
S1538	177
S1550	177
S1916	179
V1536/ P3964	193
V1538/ G4396	194
V1539/ G4391	193
V1540/ G4394	193

FLATWARE

Item #	Page
ELG01	243
EQ283	234
EQ284	234
EQ285	234
EQ286	234
EQ287	234
EQ288	234
EQ289	234
EQ290	234
EQ291	234
EQ292	234
EQ293	234
EQ294	234
EQ295	234, 243
ESK01	242
FG701	239
FG704	239
FG706	239
FG709	239
FG718	239
FG726	239, 243
FG727	221
FG728	239
FG729	239
FJ506	243
FJ507	243
FJ508	243
FJ509	242
FJ516	242
FJ517	242
FJ605	242
FJ611	242
FJ612	242
FJ701	221
FJ704	221
FJ706	221
FJ708	221
FJ709	221
FJ801	236
FJ804	236
FJ806	236
FJ828	236
FJ829	236

Item #	Page
FJ909	236
FJ911	236
FK307	242
FK401	224
FK404	224
FK406	224
FK428	224
FK429	224
FK491	242
FK501	225
FK504	225
FK506	225
FK528	225
FK529	225
FK603	242
FK801	220
FK802	220
FK804	220
FK806	220
FK809	220
FK828	220
FK829	220
FL101	241
FL102	241
FL104	241
FL106	241
FL109	241
FL118	241
FL121	241
FL128	241
FL129	241
FL201	219
FL202	219
FL204	219
FL206	219
FL209	219
FL211	219
FL218	219
FL221	219
FL227	219
FL228	219
FL229	219
FL301	222
FL302	222

Item #	Page
FL304	222
FL306	222
FL309	222
FL311	222
FL318	222
FL321	222
FL327	222
FL328	222
FL329	222
FL401	240
FL402	240
FL404	240
FL406	240
FL409	240
FL418	240
FL428	240
FL429	240
FL501	239
FL502	239
FL504	239
FL506	239
FL509	239
FL518	239
FL528	239
FL529	239
FL601	238
FL602	238
FL604	238
FL606	238
FL609	238
FL618	238
FL621	238
FL627	238
FL628	238
FL629	238
FL701	219
FL702	219
FL704	219
FL706	219
FL709	219
FL711	219
FL718	219
FL721	219
FL727	219

FLATWARE

Item #	Page
FL728	219
FL729	219
FL801	218
FL802	218
FL804	218
FL806	218
FL809	218
FL828	218
FL829	218
FL886	229
FL901	216
FL902	216
FL904	216
FL906	216
FL909	216
FL913	216
FL927	216
FL928	216
FL929	216
FL940	216
FL941	229
FL942	229
FL946	229
FL947	229
FL948	229
FL951	229
FL952	229
FL953	229
FM301	221
FM304	221
FM306	221
FM328	221
FM329	221
FM501	240
FM502	240
FM504	240
FM505	240
FM506	240
FM509	240
FM518	240
FM528	240
FM529	240
FM530	240
FM571	228

Item #	Page
FM575	228
FM577	228
FM578	228
FM579	228
FM580	228
FM581	228
FM582	228
FM583	228
FM584	228
FM601	237
FM604	237
FM606	237
FM609	237
FM611	237
FM627	237
FM628	237
FM629	237
FM711	225
FM721	225
FMO05	216
FMO06	242
FMO08	216
FMO12	216
FMO26	216 , 243
FN405	233
FN727	242
FN995	217
FN996	217
FN997	217
FN998	217
FP001	217
MB200	227
MB201	227
MB202	227
MB203	227
MB204	227
MB205	227
MB206	227
MB207	227
MB208	227
MB212	227
MB219	227
MB220	227
MB221	226

Item #	Page
MB222	226
MB223	226
MB224	226
MB225	226
MB226	226
MB227	226
MB228	226
MB232	226
MB233	226
MB234	226
MB235	226
MB236	226
MB237	226
MB238	226
MB239	226
MB240	226
MB241	226
MB242	226
MB243	226
MB244	226
MB245	227
MB246	227
MB247	227
MB248	227
MB249	227
MB250	227
MB251	227
MB252	227
MB253	227
MB254	227
MB255	228
MB256	228
MB257	228
MB258	228
MB259	228
MB260	228
MB261	228
MB262	228
MB263	228
MB264	228
MB265	229
MB266	229
MB267	229
MB268	229

FLATWARE

Item #	Page
MB269	229
MB270	229
MB271	229
MB272	229
MB273	229
MB274	229
MB275	229
MB276	229 , 243
MB277	229
MB296	231
MB297	231
MB298	231
MB299	231
MB300	231
MB301	231
MB302	231
MB303	231
MB304	231
MB305	231
MB306	231
MB307	231
MB308	231
MB309	231
MB311	231
MB312	231
MB314	231
MB315	231
MB316	231
MB317	231
MB318	231
MB319	231
MB320	231
MB321	231
MB322	232
MB323	232
MB324	232
MB325	232
MB326	232
MB327	232
MB328	232
MB329	232
MB331	232
MB337	232
MB339	232

Item #	Page
MB341	232
SCP99	230
SCR98	230
SOE01	230
SOE02	230
SOE04	230
SOE05	230
SOE06	230
SOE08	230
SOE10	230
SOE11	230
SOE20	230
SOE28	230
SOL01	232
SOL02	232
SOL04	232
SOL05	232
SOL06	232
SOL08	232
SOL10	232
SOL11	232
SOL13	232
SOL20	232
SOL28	232
SOM01	233
SOM02	233
SOM04	233
SOM05	233
SOM06	233
SOM08	233
SOM10	233
SOM11	233
SOM13	233
SOM20	233
SOM28	233
T0417	216
T0418	216
T0421	216
T0422	216
T0424	216
T0425	216
T0426	216 , 243
T1801	238
T1802	238

Item #	Page
T1804	238
T1805	238
T1806	238
T1808	238
T1809	238
T1811	238
T1812	234
T1813	234
T1816	234
T1817	234
T1818	234
T1819	234
T1820	234
T1821	234
T1822	234
T1823	234
T1824	234
T1825	234
T1826	234 , 243
T1828	238
T1829	238
T1901	236
T1902	236
T1904	236
T1906	236
T1909	236
T1911	236
T1928	236
T1929	236
T3501	235
T3502	235
T3504	235
T3505	235
T3506	235
T3528	235
T3529	235
T3601	235
T3602	235
T3604	235
T3605	235
T3606	235
T3608	235
T3609	235
T3611	235

FLATWARE

Item #	Page
T3621	235
T3627	235
T3628	235
T3629	235
T4701	222
T4702	222
T4704	222
T4706	222
T4708	222
T4709	222
T4710	222
T4711	222
T4727	216
T4728	222
T4729	222
T4801	223
T4802	223
T4804	223
T4806	223
T4809	223
T4811	223
T4827	223
T4828	223
T4829	223
T4901	224
T4902	224
T4904	224
T4905	224
T4906	224
T4908	224
T4909	224
T4910	224
T4911	224
T4918	224
T4927	224
T4928	224
T4929	224
T5101	217
T5102	217
T5104	217
T5105	217
T5106	217
T5109	217
T5110	217

Item #	Page
T5111	217
T5118	217
T5121	217
T5127	217
T5128	217
T5129	217
T5201	218
T5202	218
T5204	218
T5206	218
T5209	218
T5211	218
T5221	218
T5227	218
T5228	218
T5229	218
T5401	220
T5402	220
T5404	220
T5405	220
T5406	220
T5408	220
T5409	220
T5410	220
T5411	220
T5427	220
T5428	220
T5429	220
T7801	241
T7802	241
T7804	241
T7805	241
T7806	241
T7808	241
T7810	241
T7811	241
T7828	241
T7829	241
T8001	237
T8002	237
T8004	237
T8006	237
T8008	237
T8009	237

Item #	Page
T8011	237
T8018	237
T8028	237
T8029	237
T9010	223
T9011	223

SMALLWARES · BUFFET

Item #	Page
FN169	282
FN171	282
FN175	283
FN176	283
FN177	283
FN178	283
FN179	283
FN180	283
FN181	285
FN182	285
FN183	285
FN184	285
FN185	285
FN186	285
FN187	288
FN188	288
FN189	288
FN190	288
FN192	289
FN193	289
FN194	289
FN195	289
FN196	289
FN197	289
FN198	289
FN199	289
FN200	289
FN201	286
FN202	287
FN203	287
FN204	287
FN205	287
FN206	287
FN207	287
FN208	287
FN209	287
FN210	287
FN211	287
FN212	287
FN213	287
FN214	287
FN215	290
FN216	282

Item #	Page
FN217	290
FN218	290
FN219	290
FN220	290
FN221	290
FN222	290
FN223	290
FN224	290
FN225	290
FN226	291
FN227	291
FN228	291
FN229	291
FN345/ AS2710SS2	257
FN347/ AS2700SS2	257
FN348/ AS2620SS2	261
FN349/ AS2630SS2	261
FN350/ AG2800BK2	263
FN351/ AS2020SS2	259
FN352/ AS2010SS2	259
FN353/ AS2000SS2	259
FN354/ AS2020SS2COF	259
FN355/ AS2020SS2DEC	259
FN356/ AS2020SS2HW	259
FN357/ TGS10SC	269
FN361/ TGB06SC	271
FN362/ TGB10SC	271
FN363/ TGB10SCHH6	271
FN364/ TGB10SCCR6	271
FN365/ TGB10SCLF6	271
FN366/ TGB10SCML6	271
FN367/ TGB10SCSK6	271
FN368/ TGM10SC	271
FN369/ TGS06SC	269
FN370/ TGS15SC	269
FN371/ TGU1900SC6	265
FN372/ THF19SCLG4MD	267
FN373/ THF0208	267 , 272
FN417	281
FN418	281
FN419	281
FN420	281
FN421	275
FN422	275

SMALLWARES · BUFFET

Item #	Page
FN423	275
FN424	275
FN425	275
FN426	275
FN427	275
FN428	275
FN429	279
FN430	279
FN431	277
FN432	277
FN433	277
FN434	279
FN435	279
FN436	279
FN437	277
FN438	277
FN441/ RTGSDC25	267 , 269 , 272
FN442/ RTGSG25	267 , 269 , 272
FN443/ RTGSL25	267 , 269 , 272
FN444/ RTGUDC25	265 , 267 , 269 , 272
FN445/ RTGUG25	265 , 267 , 269 , 272
FN446/ RTGUL25	265 , 267 , 269 , 272
FN447/ TGB900525	272
FN448/ TGM1005125	272
FN698	287
FN949	275
FN950	275
FN951	275
FN952	275
FN976	281
FN977	281
FN978	281
FP012	251
FP016	251
FP017	251
FP018	251
FP019	251
FP020	251
FP021	249
FP022	249
FP023	249
FP024	249
FP025	249
FP026	249

Item #	Page
FP027	249
FP028	249
FP029	255
FP030	255
FP031	255
FP032	247
FP033	247
FP034	247
FP035	247
FP036	247
FP037	247
FP038	247
FP039	247
FP040	247
FP041	247
FP042	247
FP043	247
FP044	247
FP045	247
FP046	247
FP047	247
FP048	247
FP049	247
FP050	253
FP051	253
FP052	253
FP053	253
FP054	252
FP055	252
FP056	252
FP057	253
FP058	250
FP059	255
FP060	250
FP061	250
FP062	252
FP063	250
FP064	254
FP065	254
FP066	254
FP067	252
FP068	252

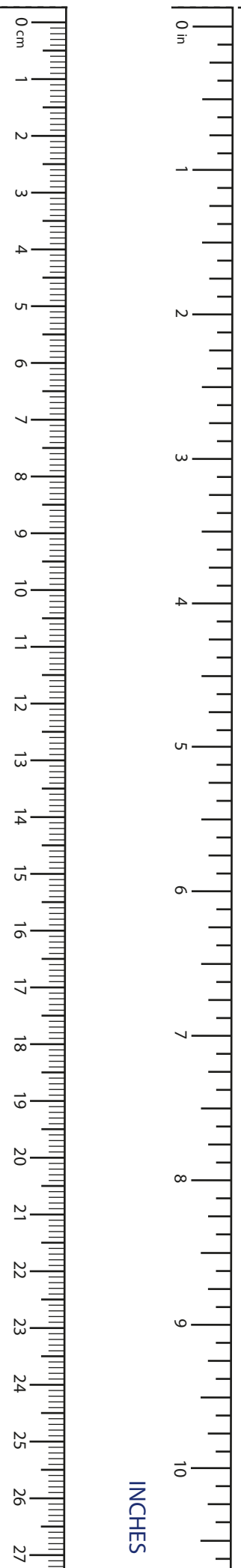

Plating/Beverage Artists

BLACKBARN Restaurant, New York, NY

Chef & Sommelier® Whiskey, *featured on page 98*

MidiCi @midici, Los Angeles, CA

Arcoroc® Pilsners, *featured on page 112*

Fresh Restaurant, Toronto/ Los Angeles @FreshRestaurants

Chef & Sommelier® Geode, *featured on page 152*

Tin Lizzy's @TinLizzysCantina, Atlanta, GA

Arcoroc® Canyon Ridge, *featured on page 164*

Valeria Pinto @VibrantValeria, RezDóra, New York, NY

Arcoroc® Candour Azure, *featured on page 186*

CENTIMETERS

INCHES



arc
cardinal

2022 - 2023 PORTFOLIO

www.ArcCardinal.com

45A Commerce Way Totowa, NJ 07052
telephone: 973- 628- 0900
email: cardinalsales@arc-intl.com