



GAS CONVECTION OVEN

Model	Product ID	Gas	Racks
KCO-1	919591	Natural	5

Model	Product ID	Description
KSK-L	919592	Stacking Kit w/ 6" legs and interconnecting plumbing, for double deck unit
KSK-C	919593	Stacking Kit w/ casters and interconnecting plumbing, for double deck unit

STANDARD FEATURES

Construction

- All stainless steel construction
- Double pane thermal glass windows on doors
- Doors have an interlock switch that automatically turns the fan & burners off when open
- 3/4" NPT rear gas connection

Oven Features

- Oven interior measures 28 1/4" x 21 1/2" x 20"
- 1/2 HP two-speed fan motor
- Cooking chamber is lined w/ porcelain enamel
- 10 position guide rack w/ 1 1/2" spacing in between
- Includes (5) heavy duty adjustable chrome-plated racks
- Seamless interior & corners for easy cleaning

Controls

- 120V, 60hz controls for oven
- Temperature range from 150°F to 550°F
- 60-minute continuous ring timer w/ manual shut off
- Temperature ready indicator light
- 6' power cord w/ NEMA 5-15 plug

Legs

- Stainless steel legs w/ adjustable bullet feet

WARRANTY

Kintera Gas Cooking Equipment is warranted to be free from defects in material and workmanship under normal use and service for a period of 1 year from the date of original purchase.



Gas Regulator Included

SPECIFICATIONS

Kintera's Full Size Gas Convection Oven is ideal for any high volume restaurant or foodservice establishment. Constructed of stainless steel, this oven operates with a forced air, two-speed fan motor system with a cool down feature.

The interior of the oven has a 10 position rack guide and fits full size sheet pans. Electronic controls featuring a 60-minute timer and manual temperature chrome knob. The double pane glass doors have an interlock switch that automatically turns the fan and burners off when they are opened.

Includes stainless steel legs and adjustable bullet feet.

IMPORTANT INFORMATION

- An internal pressure regulator is provided with this unit.
 Natural Gas 4" W.C.
 Propane Gas 10" W.C.
- Units supplied with LP conversion kits.
 • 3/4" NPT rear gas connection

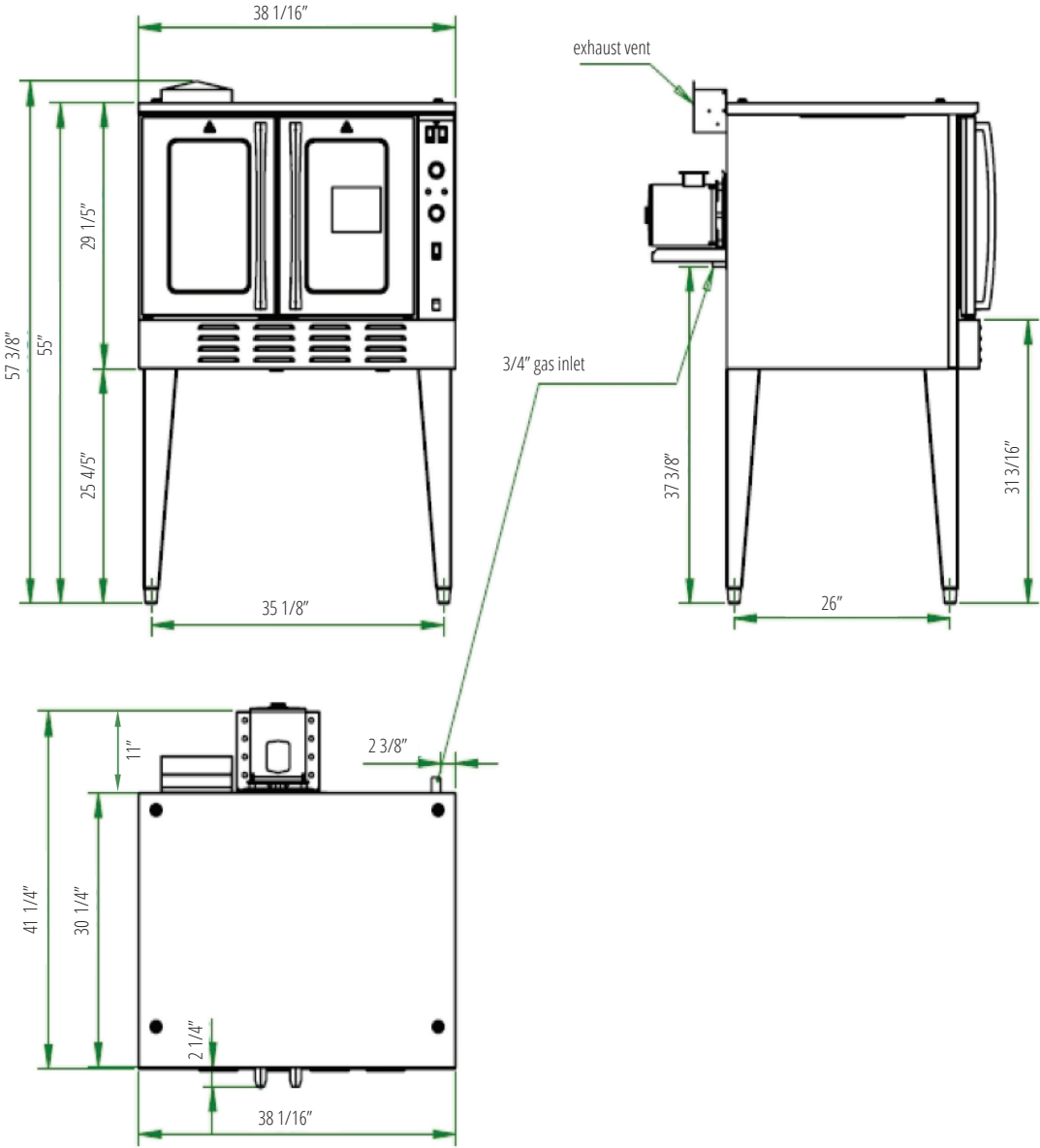

Model	Product ID	Racks	External Dimensions (in)			Internal Oven Dimensions (in)			Total BTU's	Volts	Amps	NEMA Plug	Crated Weight (lbs)
			W	D	H	W	D	H					
KCO-1	919591	5	38 1/16	41 1/4	57 3/8	28 1/2	21 1/2	20	54,000	120V	9.3	5-15	579